

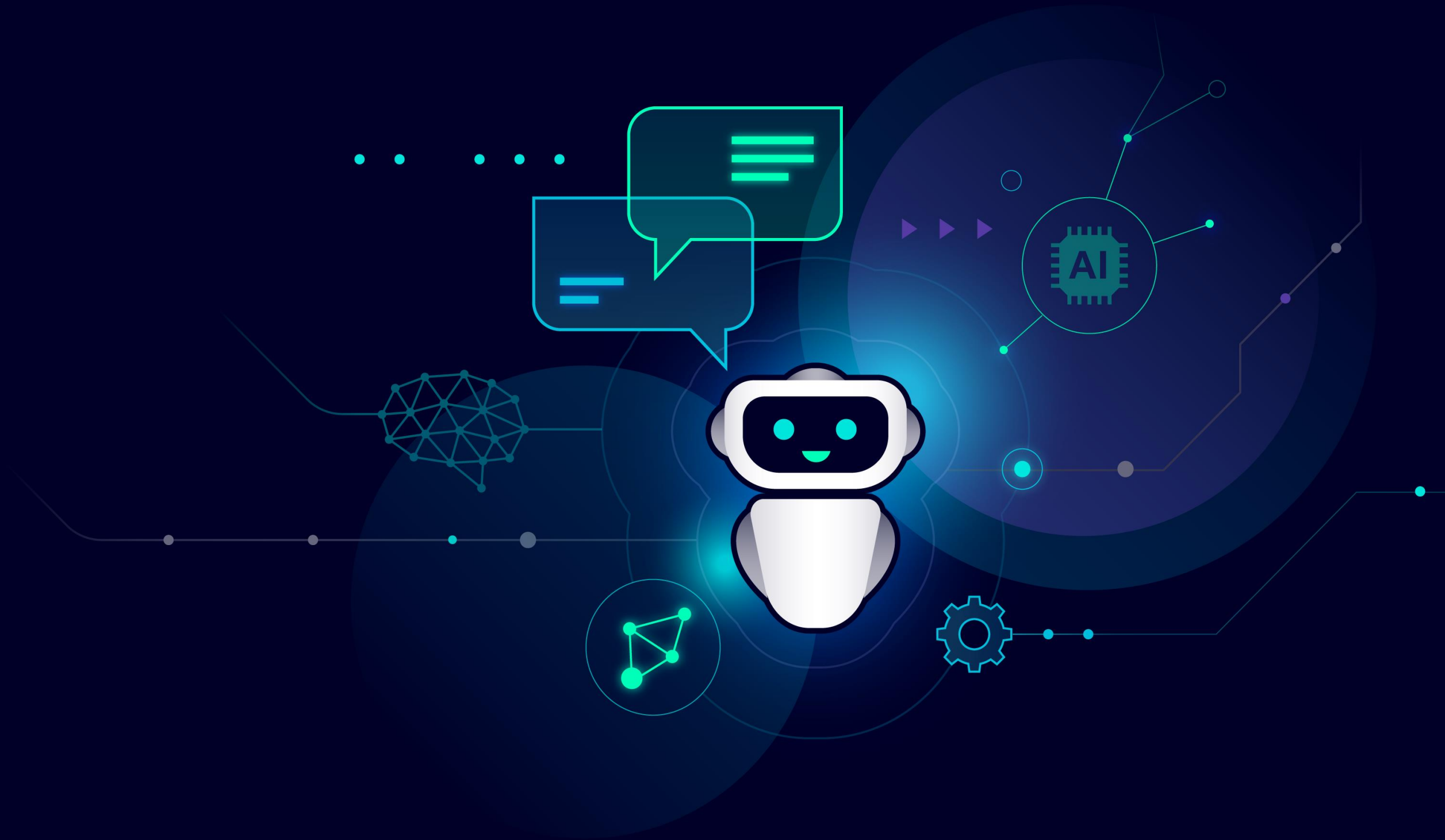



PADS Designer 활용 방법

ED&C / 김성훈



목차

 01	 02	 03	 04
PADS Designer 개요 <ul style="list-style-type: none">• PADS Designer의 소개	PADS Designer 사용 <ul style="list-style-type: none">• PADS Designer 사용 방법	PADS Designer 특징 <ul style="list-style-type: none">• PADS Designer의 이점	PADS Designer 활용 <ul style="list-style-type: none">• 확장 기능• 커스텀 기능

PADS Designer 개요

- PADS Designer는 PADS Layout과 같이 사용할 수 있는 회로도 프로그램입니다.
- PADS Logic보다 더 많은 기능과 확장을 원할 때 사용 할 수 있습니다.
- PADS Layout은 같은 제작사의 회로도 프로그램을 사용해야 안정성을 유지합니다.

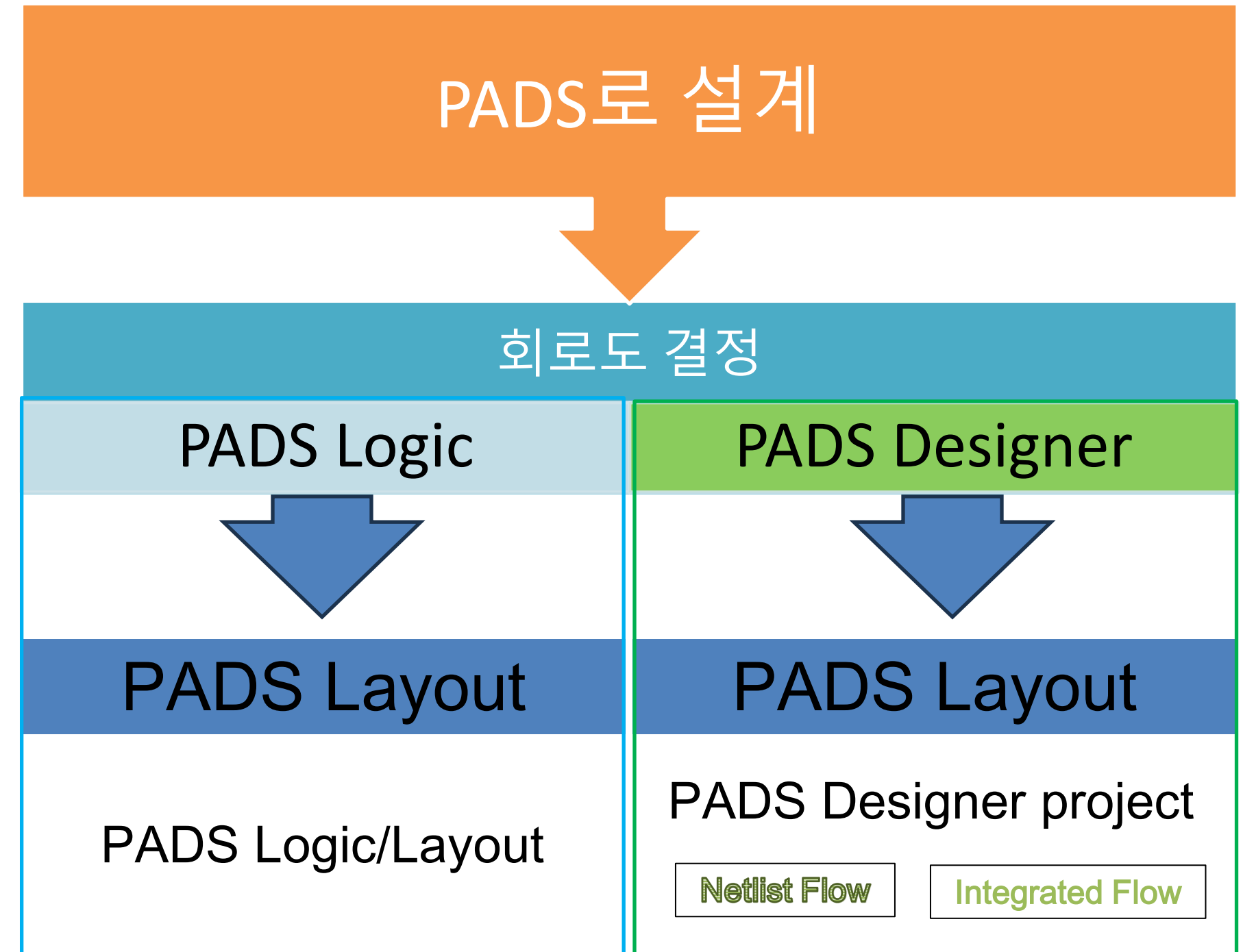

PADS Designer 개요

- PADS Designer를 선택하면 다시 2가지 방식으로 나누어 설계가 가능합니다.

	Netlist Flow(연결 설계)	Integrated Flow(통합 설계)
라이브러리의 통합 여부	회로와 PCB 라이브러리를 별도로 작성	회로와 PCB 라이브러리를 통합으로 작성
회로도-PCB 데이터의 통합 여부	회로와 PCB가 별도 관리	회로와 PCB의 통합 관리

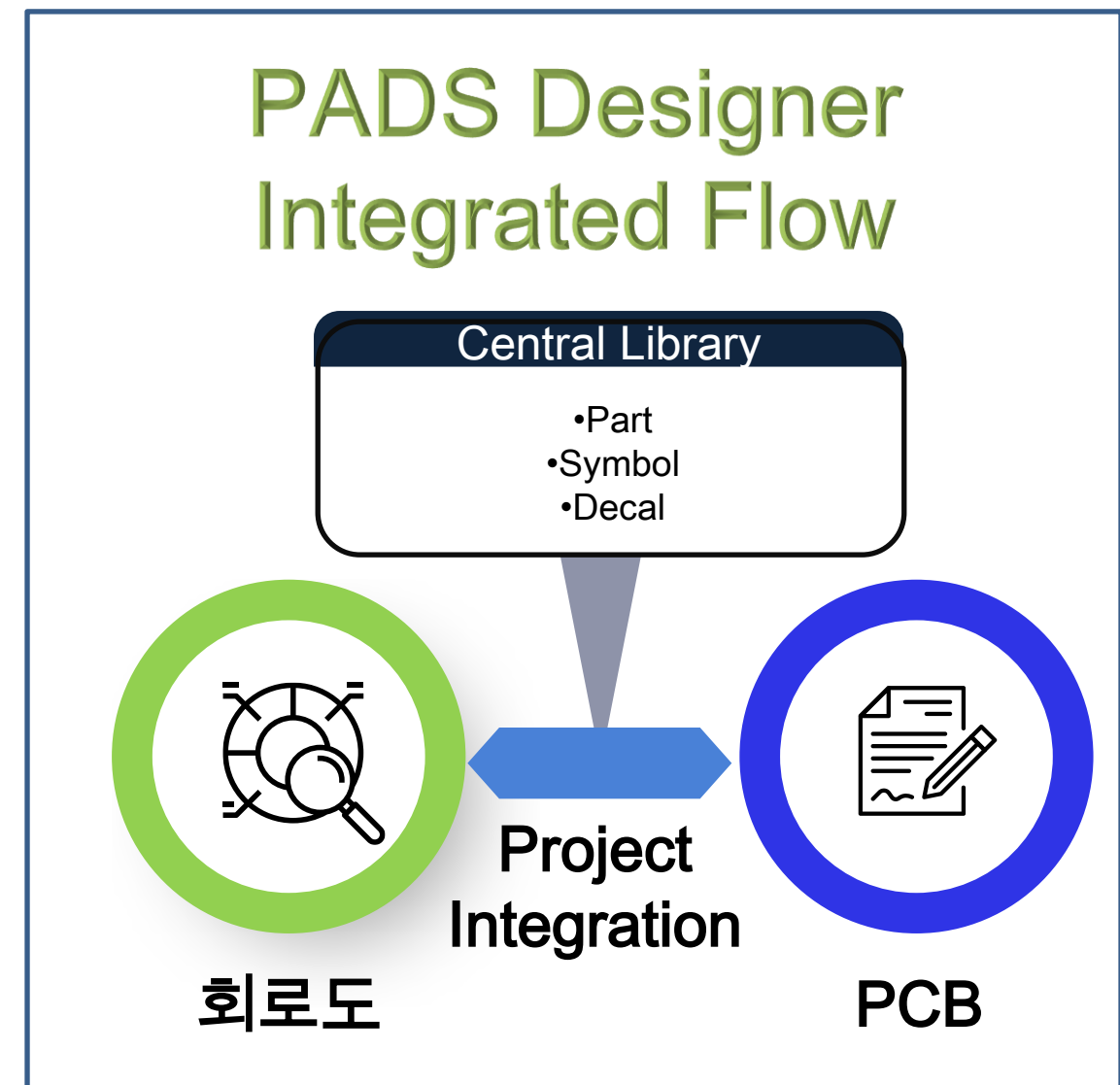
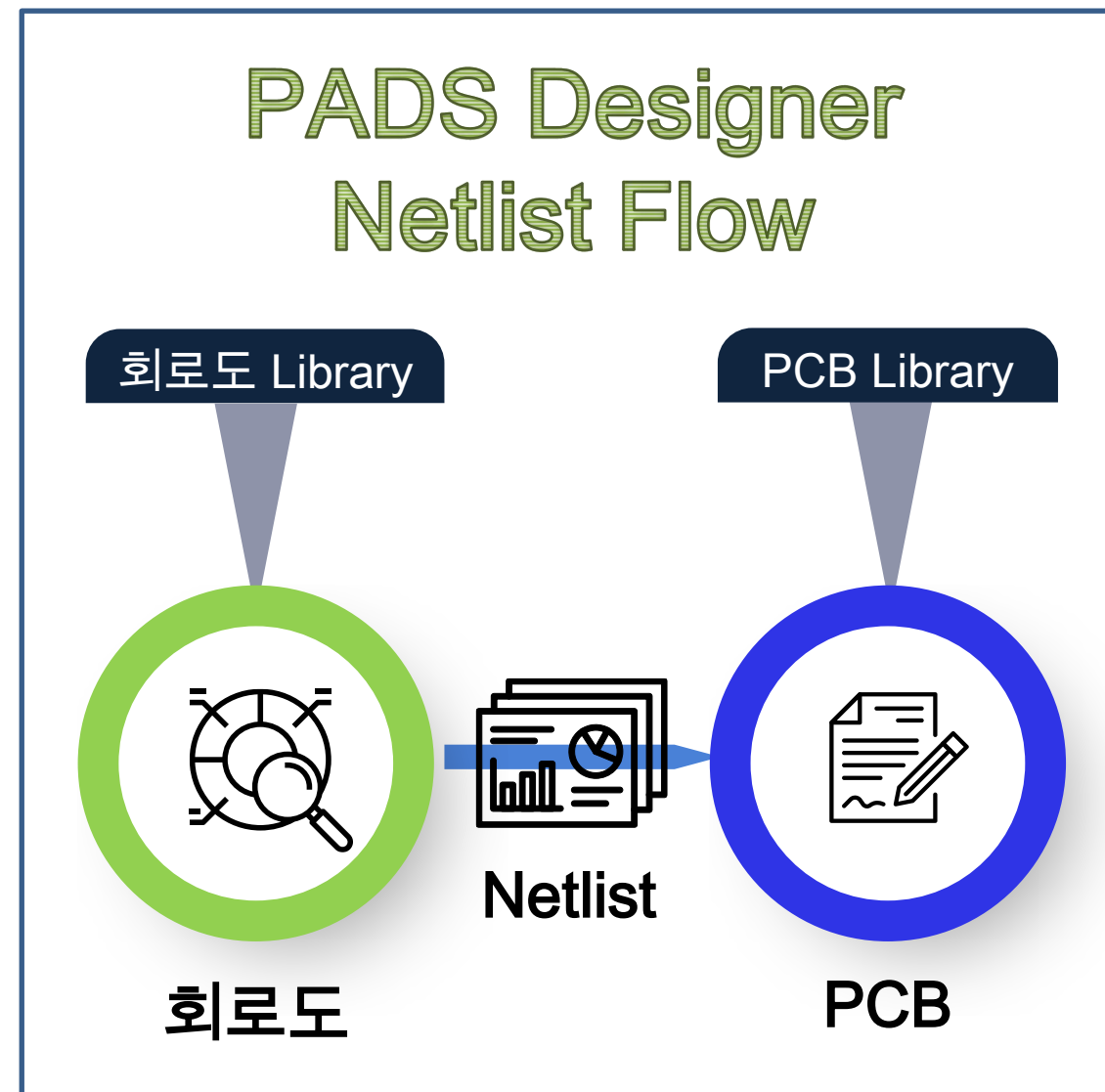
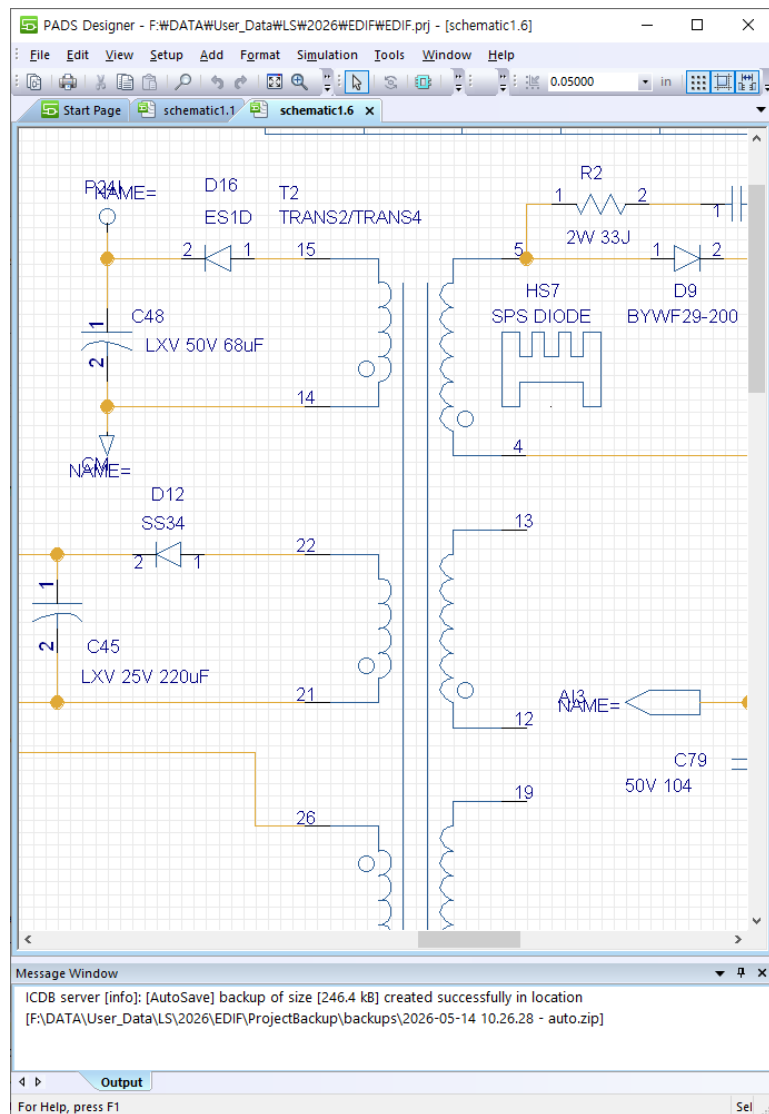

PADS Designer 개요

- 회로도 선택에 따라 라이브러리-프로젝트와 회로도-PCB 데이터의 통합성 높음

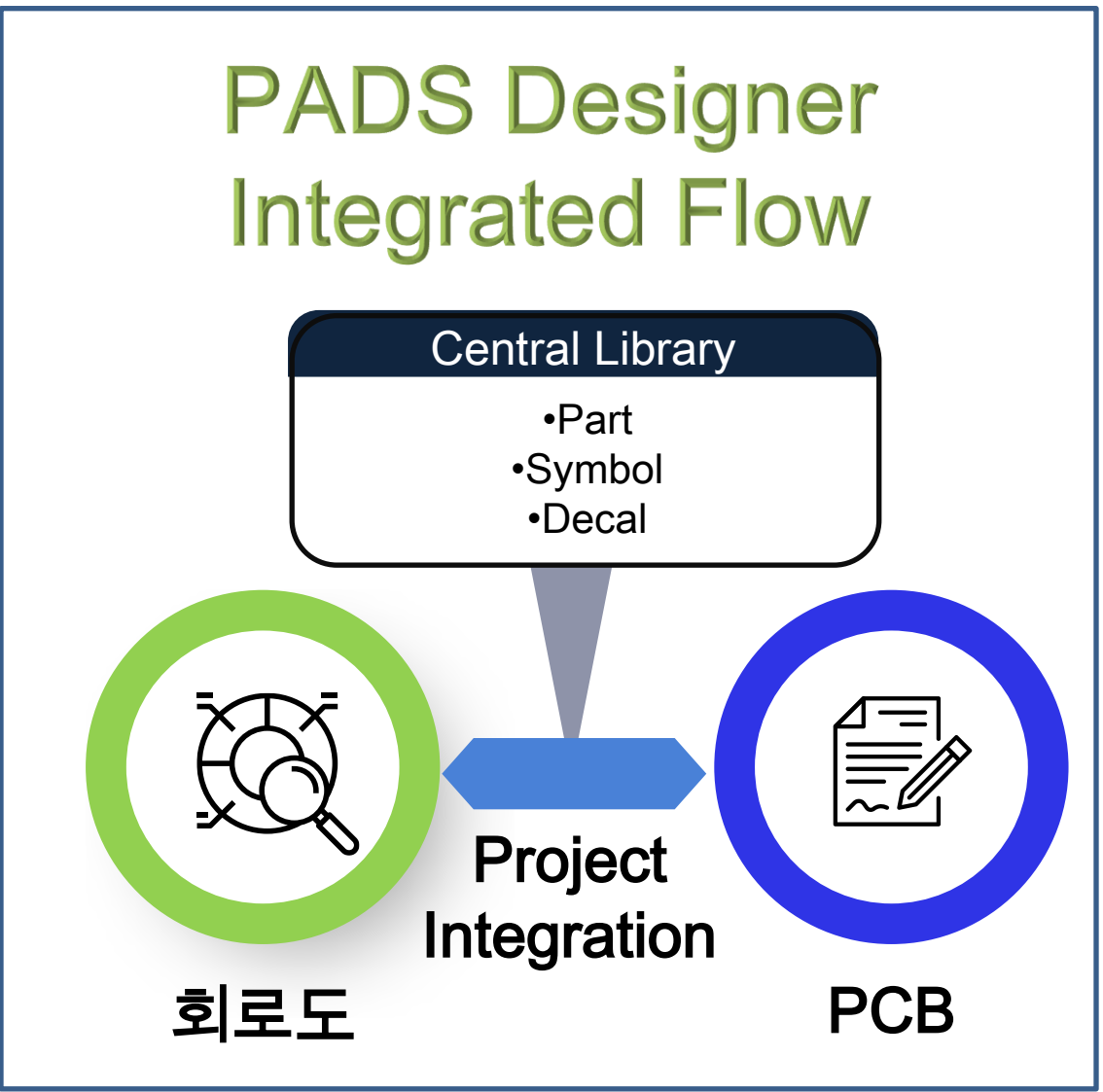
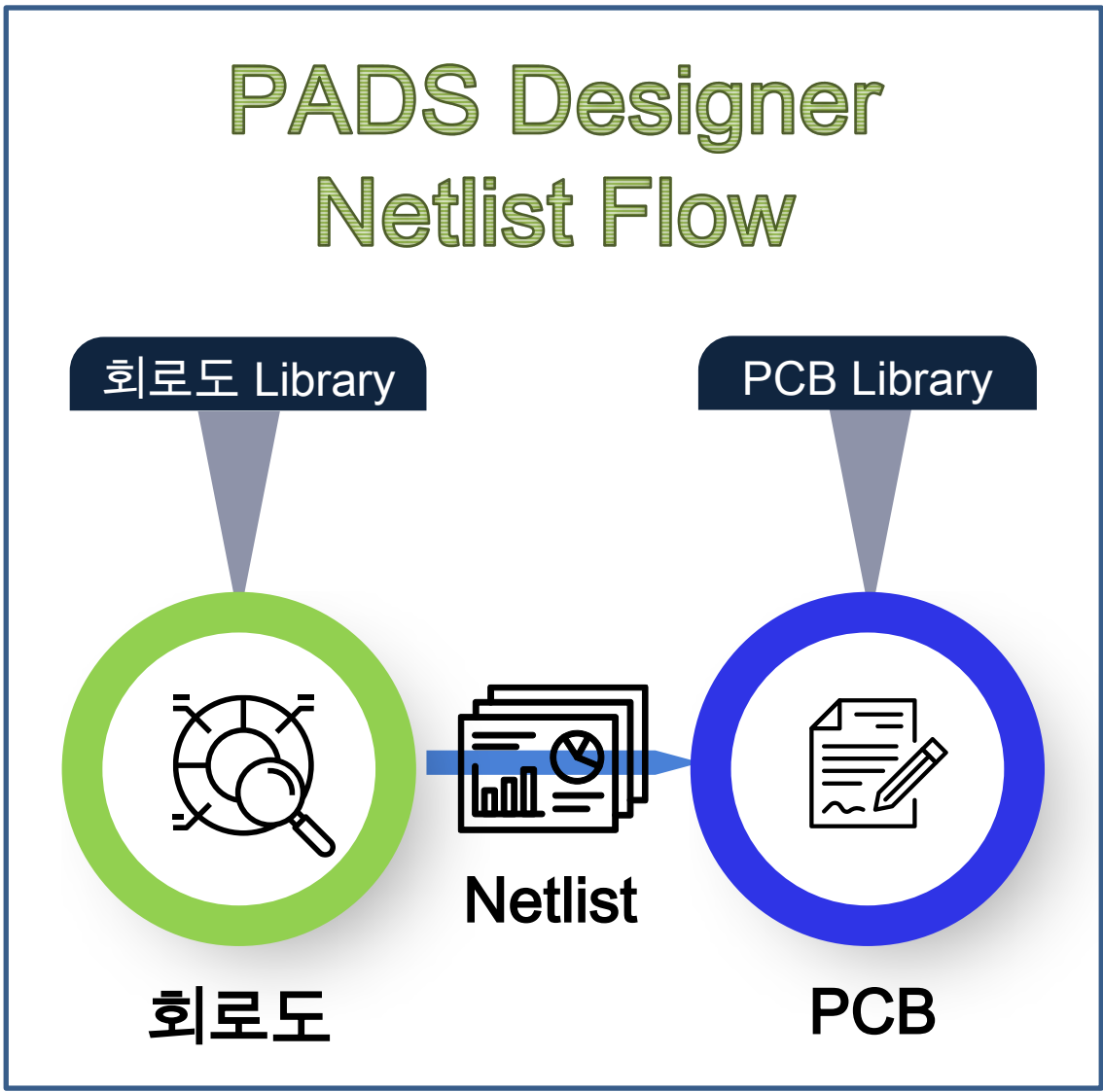
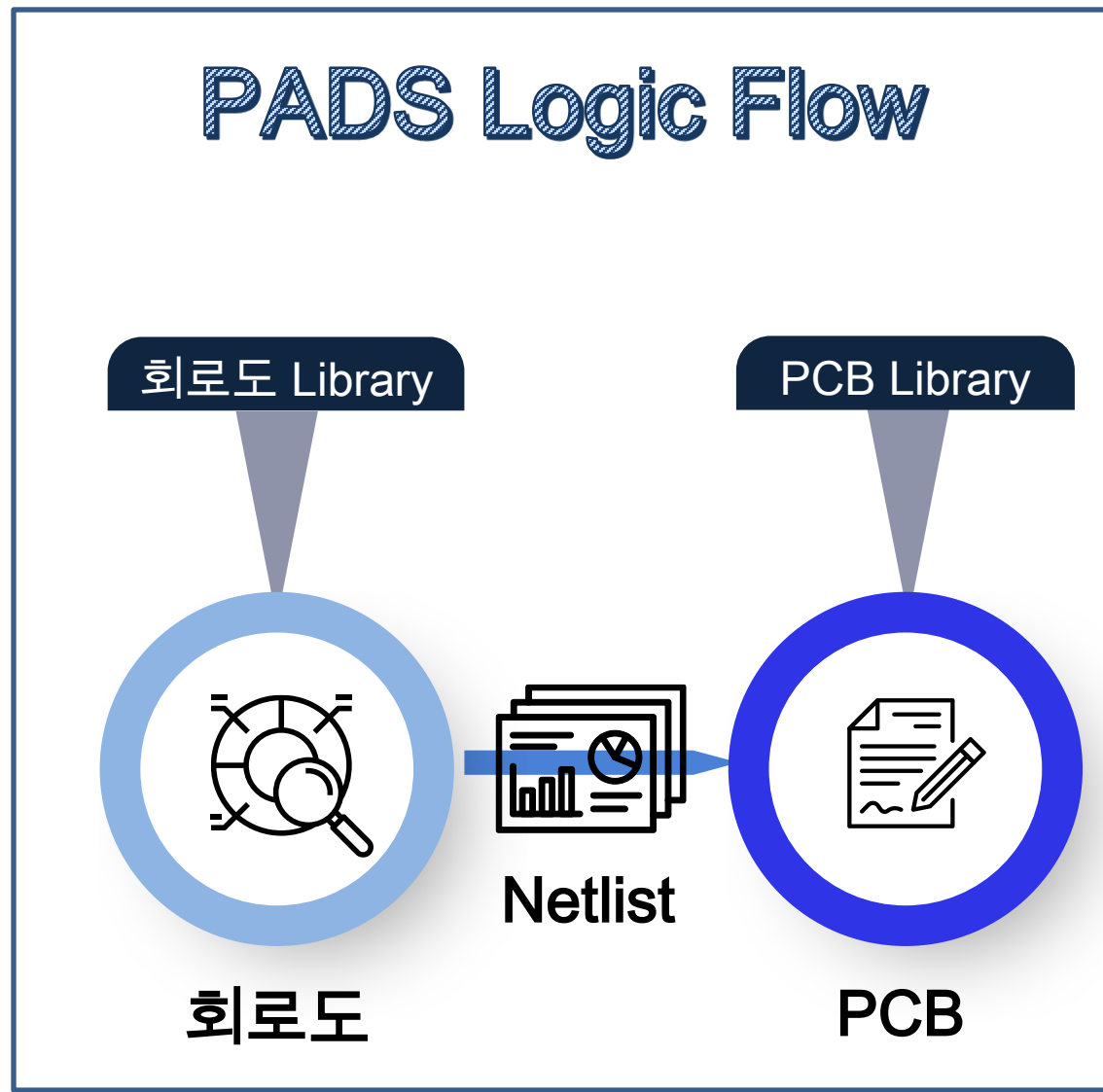

라이브러리-프로젝트/회로도-PCB데이터의 통합

PADS Designer 개요

- Designer는 SIEMENS PCB Layout의 회로도 표준으로 사용법이 같습니다.

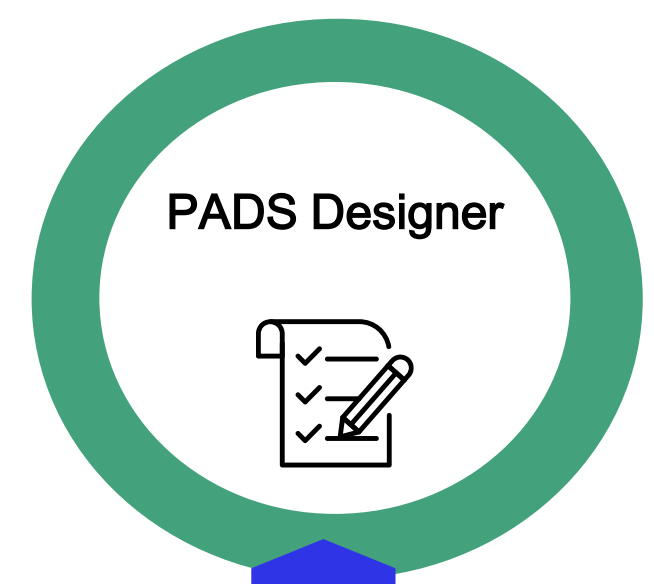

PADS Designer

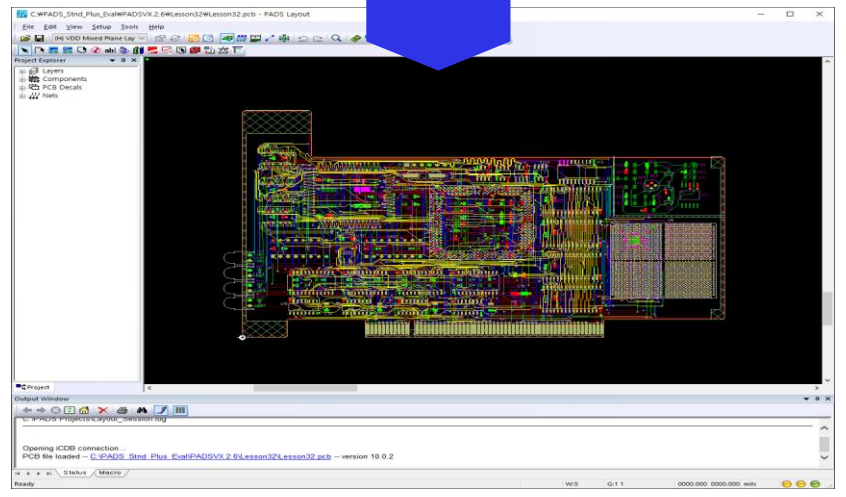

PADS

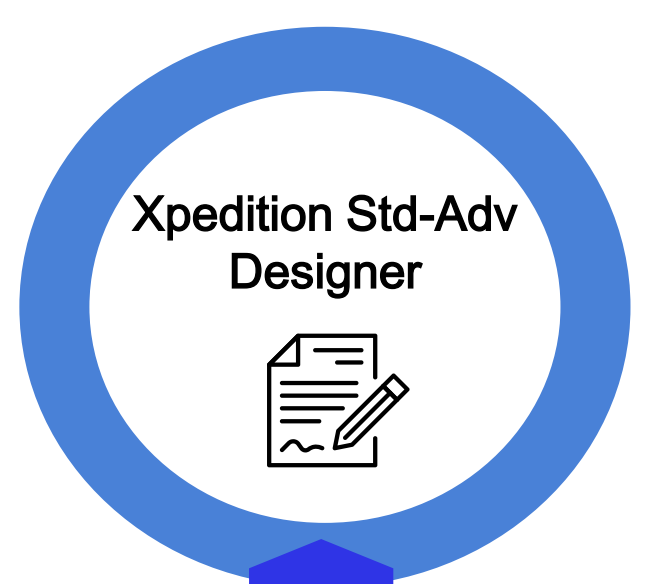

Xpedition Std-Adv Designer

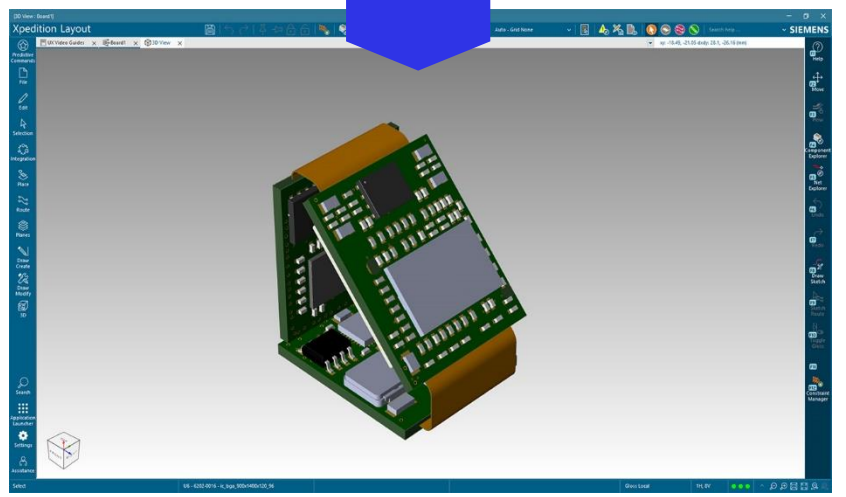

XPEDITION STANDARD

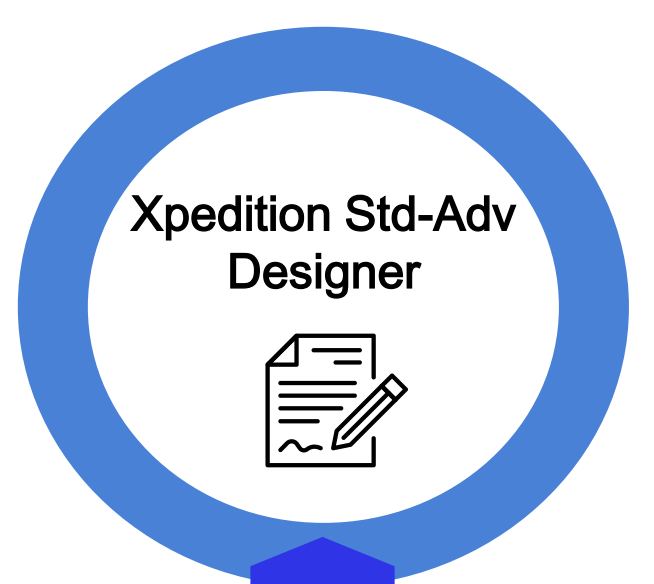

Xpedition Std-Adv Designer

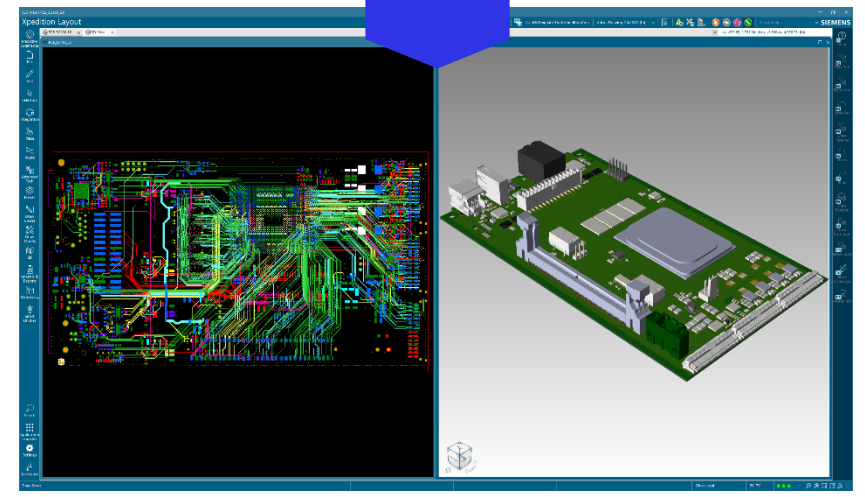

XPEDITION ADVANCED

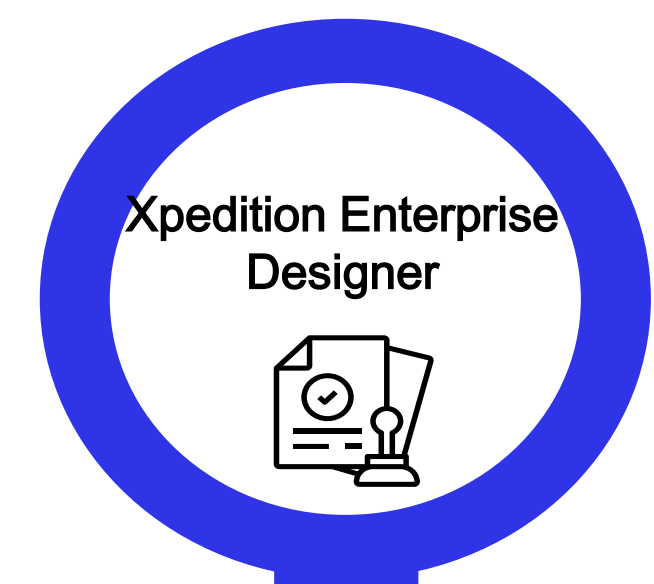

Xpedition Enterprise Designer

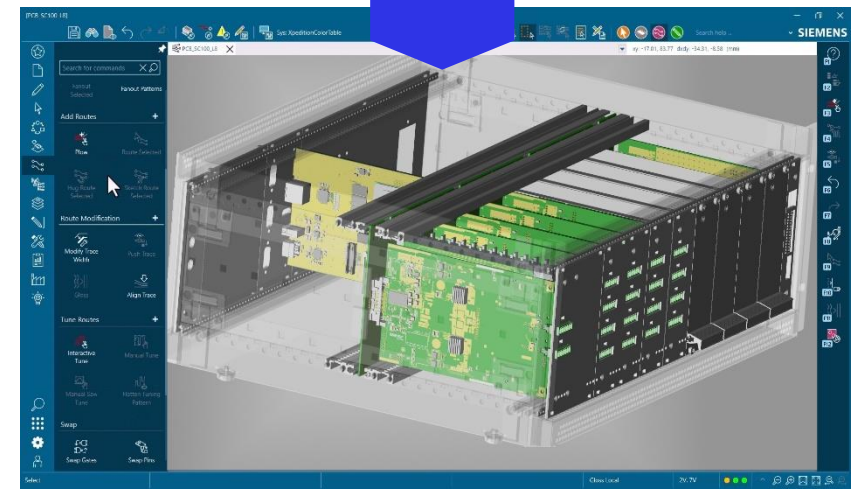

XPEDITION ENTERPRISE

PADS Designer 사용

- PADS의 설치과정에서 PADS Designer를 선택하면 설치됩니다.
- 라이선스는 PADS의 회로도 라이선스만 보유하고 있으면 가능합니다.

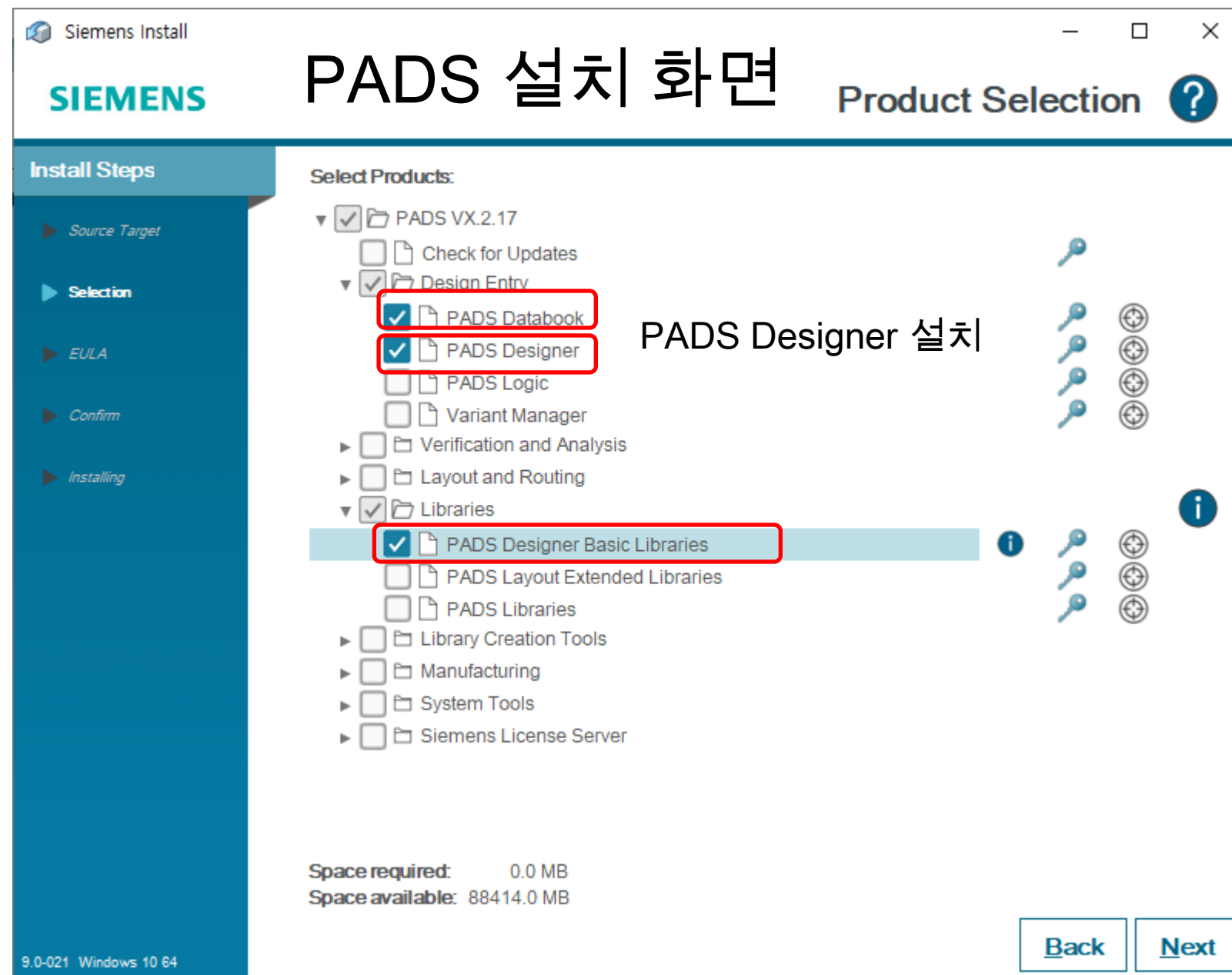

PADS 회로도 라이선스

- PADS 회로도 라이선스
- PADS 번들 라이선스

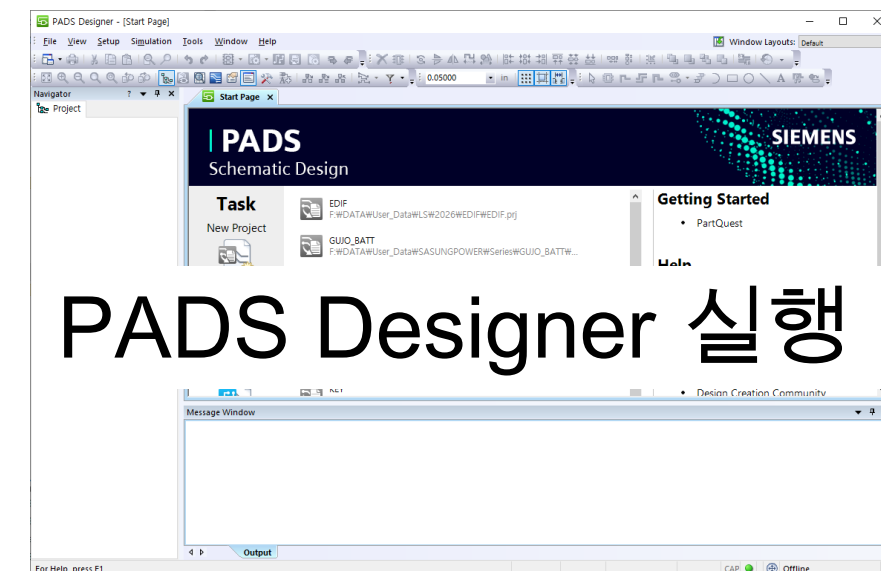
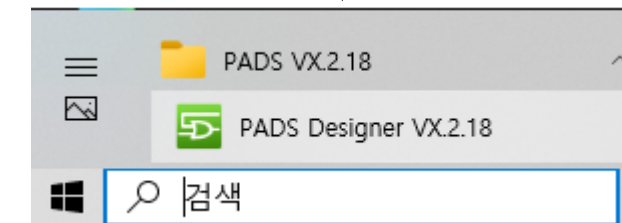

PADS Designer 사용

- Xpedition의 설치과정에서 Xpedition(std/adv/ent) Designer를 선택해 설치합니다.
- 라이선스는 Xpedition(std/adv)는 포함 이고, Xpedition Enterprise는 별도입니다.

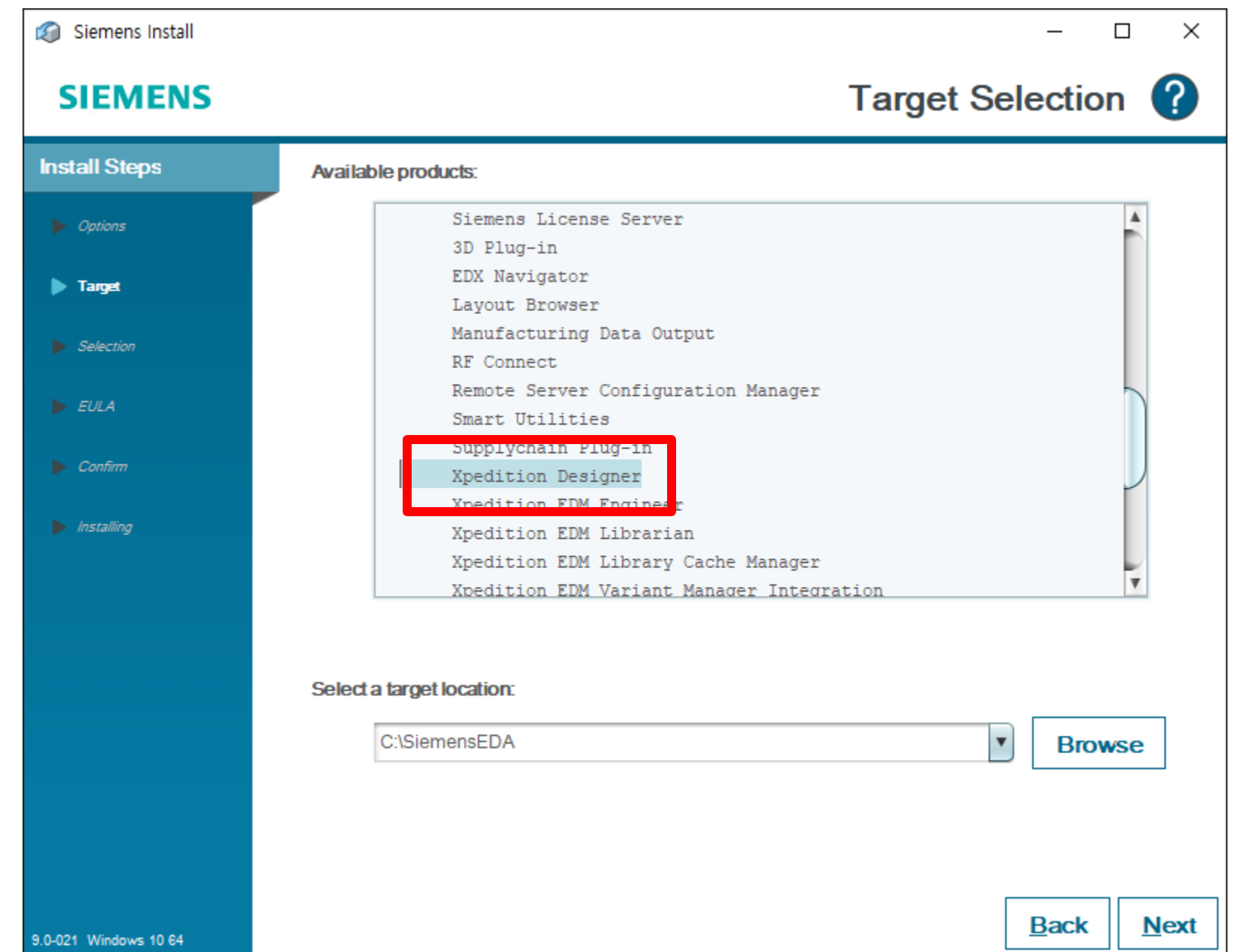
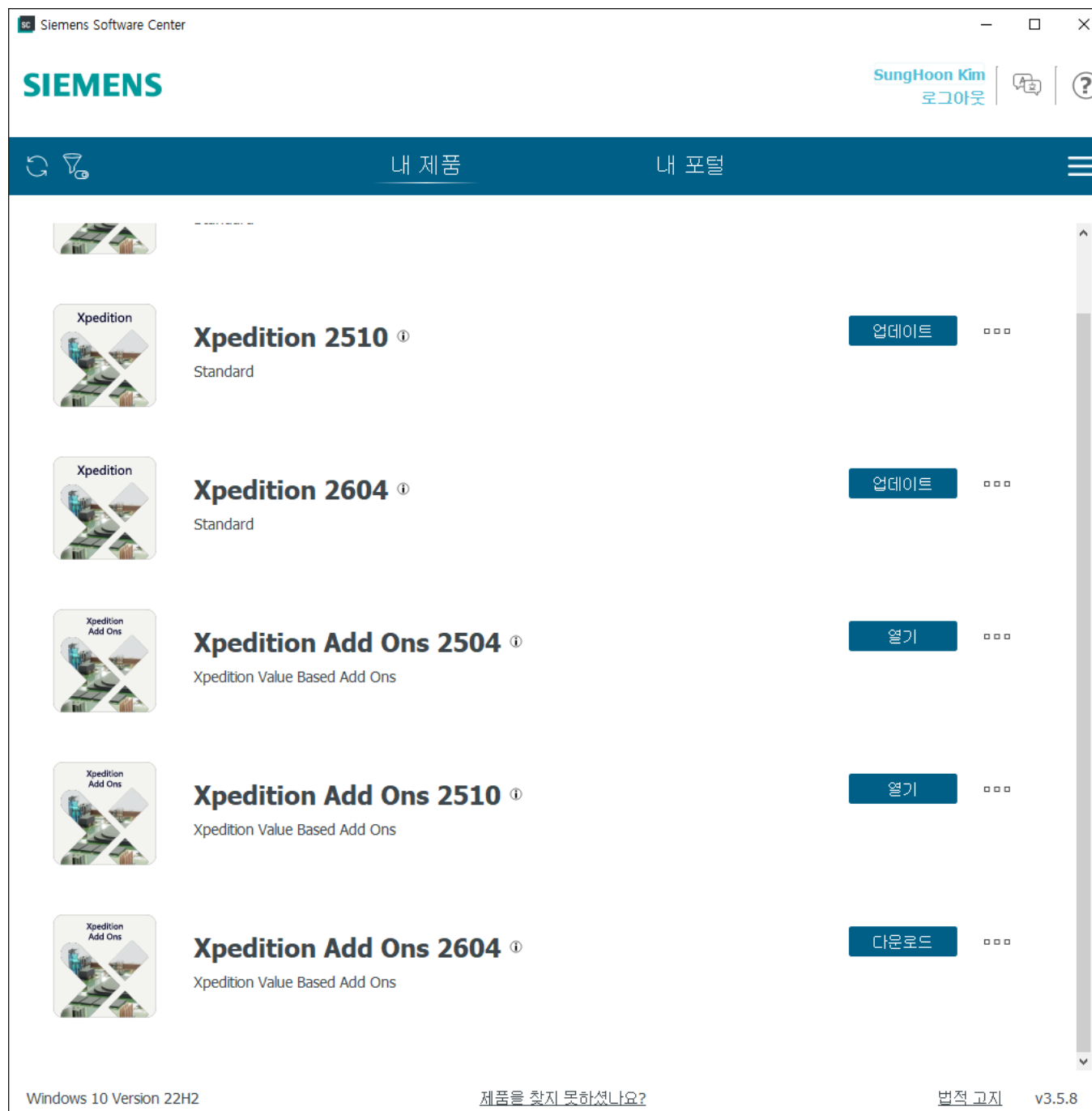

PADS Designer 사용

• PADS Designer 사용 방법

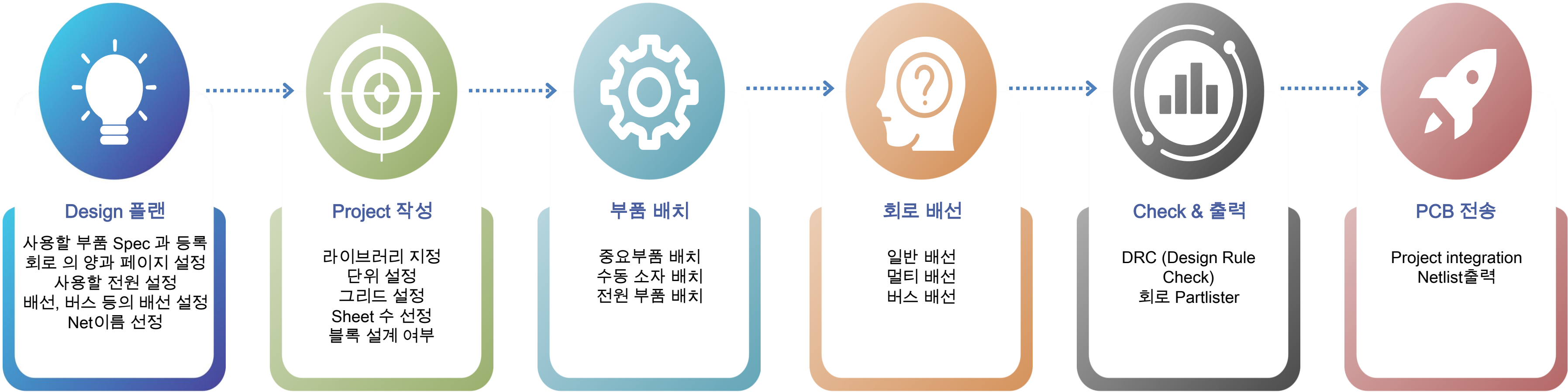

PADS Designer 사용

- PADS Designer 사용 방법



Design 플랜

사용할 부품 Spec 과 등록
회로 의 양과 페이지 설정
사용할 전원 설정
배선, 버스 등의 배선 설정
Net이름 선정

사용할 부품 Spec 과 등록

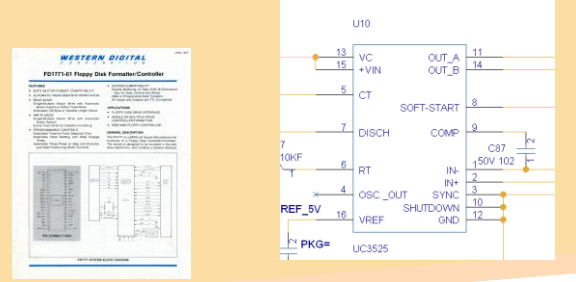

회로의 양과 페이지 설정

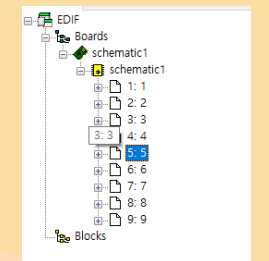

전원 설정

+5V
+3.7V

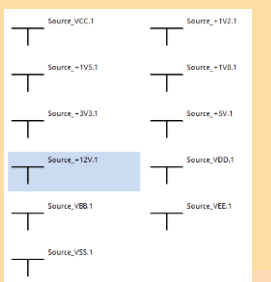

Source_VCC1	Source_VCC1
Source_VCC2	Source_VCC2
Source_VCC3	Source_VCC3
Source_VCC4	Source_VCC4
Source_VCC5	Source_VCC5
Source_VCC6	Source_VCC6
Source_VCC7	Source_VCC7
Source_VCC8	Source_VCC8
Source_VCC9	Source_VCC9
Source_VCC10	Source_VCC10
Source_VCC11	Source_VCC11
Source_VCC12	Source_VCC12
Source_VCC13	Source_VCC13
Source_VCC14	Source_VCC14
Source_VCC15	Source_VCC15
Source_VCC16	Source_VCC16
Source_VCC17	Source_VCC17
Source_VCC18	Source_VCC18
Source_VCC19	Source_VCC19
Source_VCC20	Source_VCC20
Source_VCC21	Source_VCC21
Source_VCC22	Source_VCC22
Source_VCC23	Source_VCC23
Source_VCC24	Source_VCC24
Source_VCC25	Source_VCC25
Source_VCC26	Source_VCC26
Source_VCC27	Source_VCC27
Source_VCC28	Source_VCC28
Source_VCC29	Source_VCC29
Source_VCC30	Source_VCC30
Source_VCC31	Source_VCC31
Source_VCC32	Source_VCC32
Source_VCC33	Source_VCC33
Source_VCC34	Source_VCC34
Source_VCC35	Source_VCC35
Source_VCC36	Source_VCC36
Source_VCC37	Source_VCC37
Source_VCC38	Source_VCC38
Source_VCC39	Source_VCC39
Source_VCC40	Source_VCC40
Source_VCC41	Source_VCC41
Source_VCC42	Source_VCC42
Source_VCC43	Source_VCC43
Source_VCC44	Source_VCC44
Source_VCC45	Source_VCC45
Source_VCC46	Source_VCC46
Source_VCC47	Source_VCC47
Source_VCC48	Source_VCC48
Source_VCC49	Source_VCC49
Source_VCC50	Source_VCC50

Design Plan

배선, 설정
배선 방법,
Link 여부

버스 설정
버스 단축 이름 설정

Net 이름
누구나 알 수
있는 이름

PADS Designer 사용

- PADS Designer 사용 방법

Project 작성

라이브러리 지정
단위 설정
그리드 설정
Sheet 수 선정
블록 설계 여부

Project 작성

Project 설정

Block 설계 여부

The screenshot shows the 'New Project' dialog with 'PADS' selected under 'Project Templates'. The 'Settings' dialog is open, showing a tree view of project settings like 'Boards', 'Symbol Libraries', and 'Schematic Editor'. Below, a schematic diagram shows various components like GTH230, PS 502, and GTH130, with callouts pointing to specific blocks and their page references.

PADS Designer 사용

- PADS Designer 사용 방법



부품 배치

- 중요부품 배치
- 수동 소자 배치
- 전원 부품 배치

PCB 부품 확인과 대체 부품 선정

즐거 찾기

Array

Add a rectangular or diagonal array of objects (VIDEO)

Array

Rectangular array

Number of Rows: 1

Number of Columns: 8

Diagonal vector

Number of elements: 1

OK Cancel Help

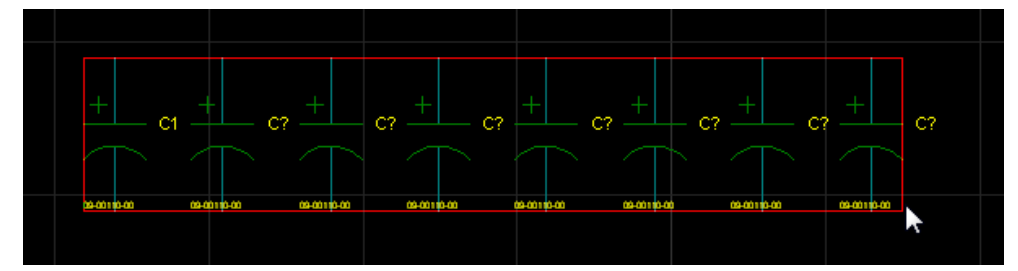
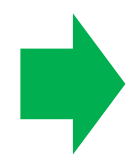

멀티 복사
기능

PADS Designer 사용

- PADS Designer 사용 방법

네트 이름 drag 변경



회로 배선

일반 배선
멀티 배선
버스 배선

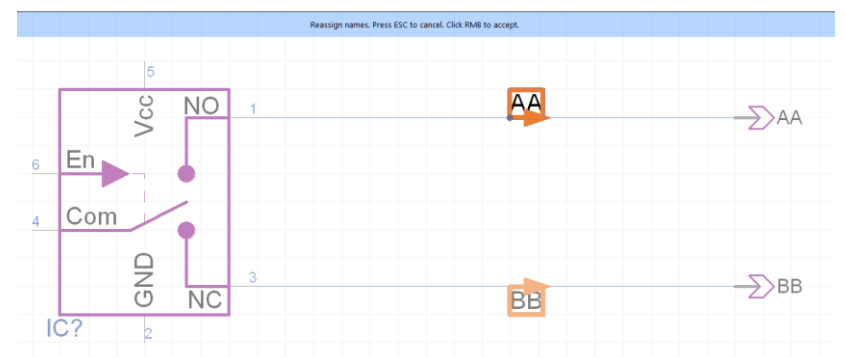

Multi-Net Connections

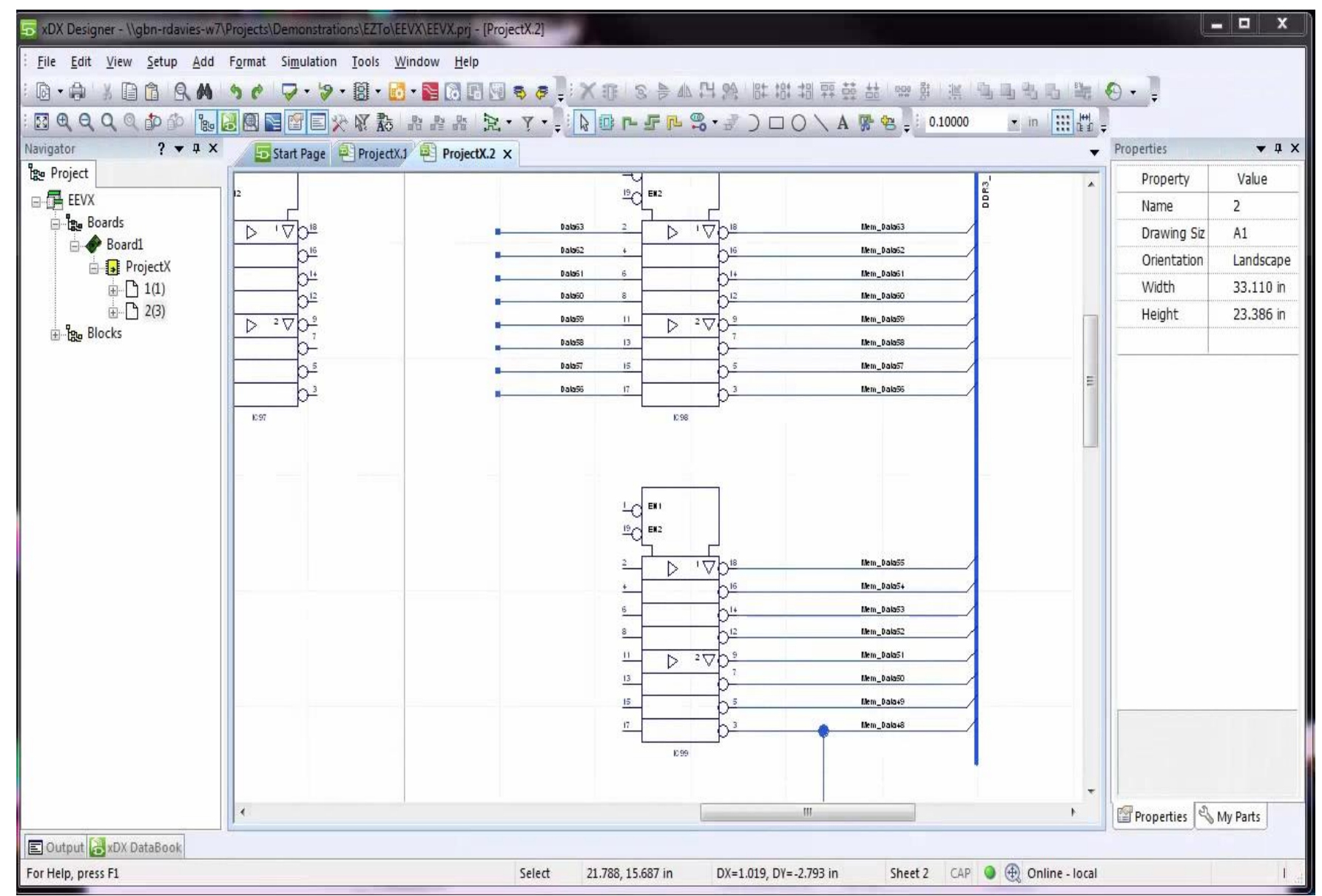

PADS Designer 사용

- PADS Designer 사용 방법

Check & 출력
DRC (Design Rule Check)
회로 Partlister

Output
Result: **OK**
Time: 0 seconds
Test: Pass-through Pins
Result: **OK**
Time: 0 seconds
Test: Empty Labels
Result: **OK**
Time: 0 seconds
Test: Connectivity
Result: **OK**
Time: 0 seconds
Test: Attributes
Result: **OK**
Time: 0 seconds
Test: Sheet Name
Result: **OK**
Time: 0 seconds
Test: Layers Consistency
Result: **OK**
Time: 0 seconds
Test: Invalid objects on layers
Result: **OK**
Time: 0 seconds
Report summary:
Tests passed: 22
Tests with error(s): 0

데이터 진단

Tools > Verify
Verify...
Package...
Constraint Editor
POWER VCC VPP

Output
Started vdr -set "C:\MGTraining\projects\DXD2007_test1\Verify.ini" -def "C:\MentorGraphics\2007EE\SDD_HOME\standard\VerifyDefaults.ini" -icdb "C:\MGTraining\projects\DXD2007_test1\database" -snapshot DxD -dxd_std -hier -block DxD2007
1526 Error(s)
GROUP: HDL Checks
→ drc-41 - [block: Memory.1 pin: MEM_BUS] Incorrect bus width connected to pin
→ drc-41 - [block: D_2_A.1 pin: MEM_BUS] Incorrect bus width connected to pin
→ drc-41 - [block: memory_array.1 pin: MEM_BUS] Incorrect bus width connected to pin

회로도 DRC

GRC
Run Graphical Rule Checker

Graphical Rules Checker

Rules	Values	Severity
<input checked="" type="checkbox"/> Net overlap		Note
<input checked="" type="checkbox"/> Object overlap		Note
<input checked="" type="checkbox"/> Net off grid		Note
<input checked="" type="checkbox"/> Pin off grid		Note
<input checked="" type="checkbox"/> Text owner	30.48 mm	Note
<input checked="" type="checkbox"/> Text alignment		Note

회로도 GRC

Off grid report
Off grid nets
No issues found
Off grid pins
No issues found

Overlapping objects report
Net overlap
Nets: RESETn, CLK_16MHz overlap

Text report
Text alignment
Texts: Value=300p, Ref Designator=C7 of \$114688 are not aligned
Texts: Value=300p, Ref Designator=C8 of \$114696 are not aligned
Texts: Value=300p, Ref Designator=C9 of \$114711 are not aligned

Text owner
No issues found

PADS Designer 사용

- PADS Designer 사용 방법

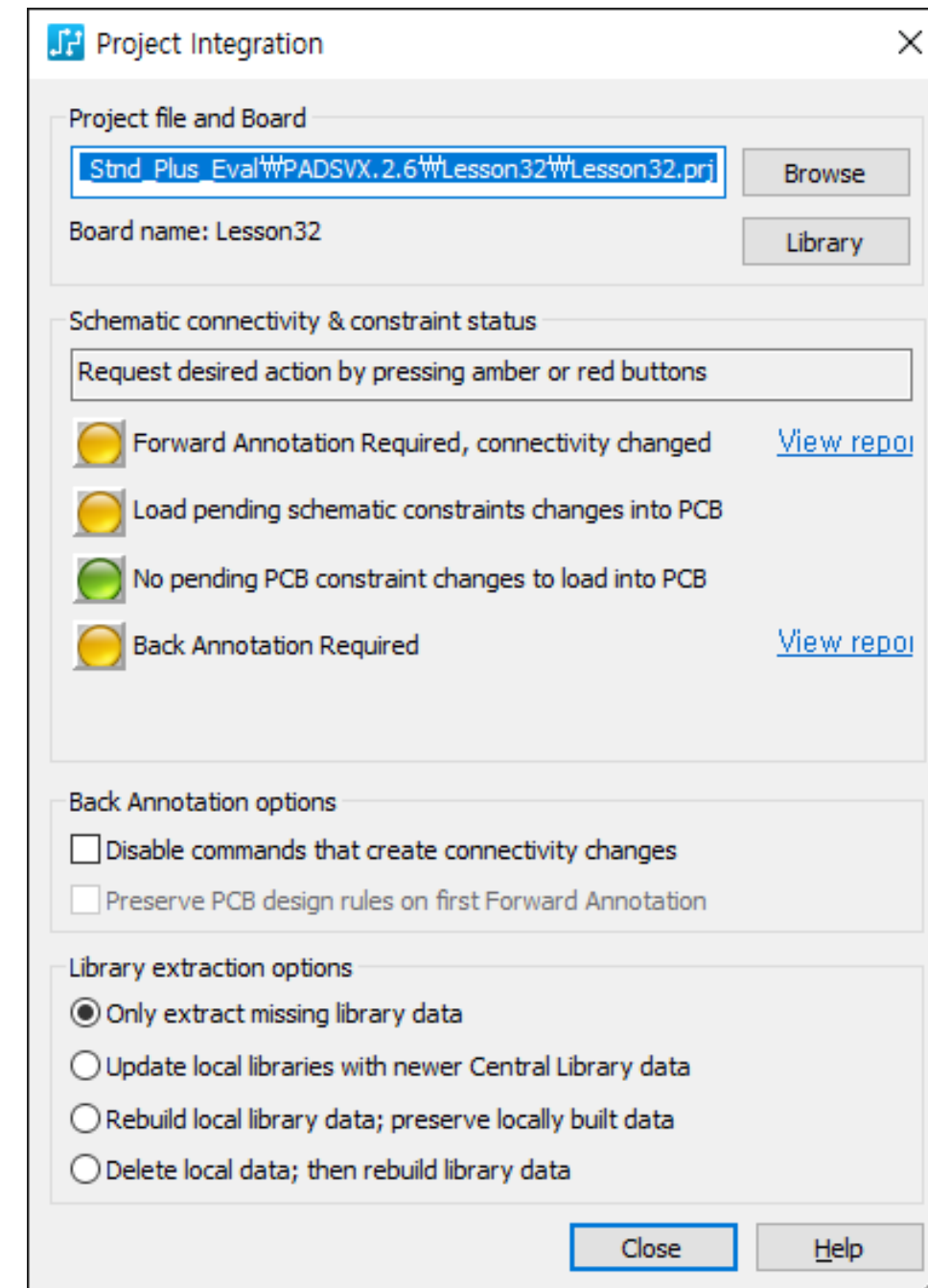
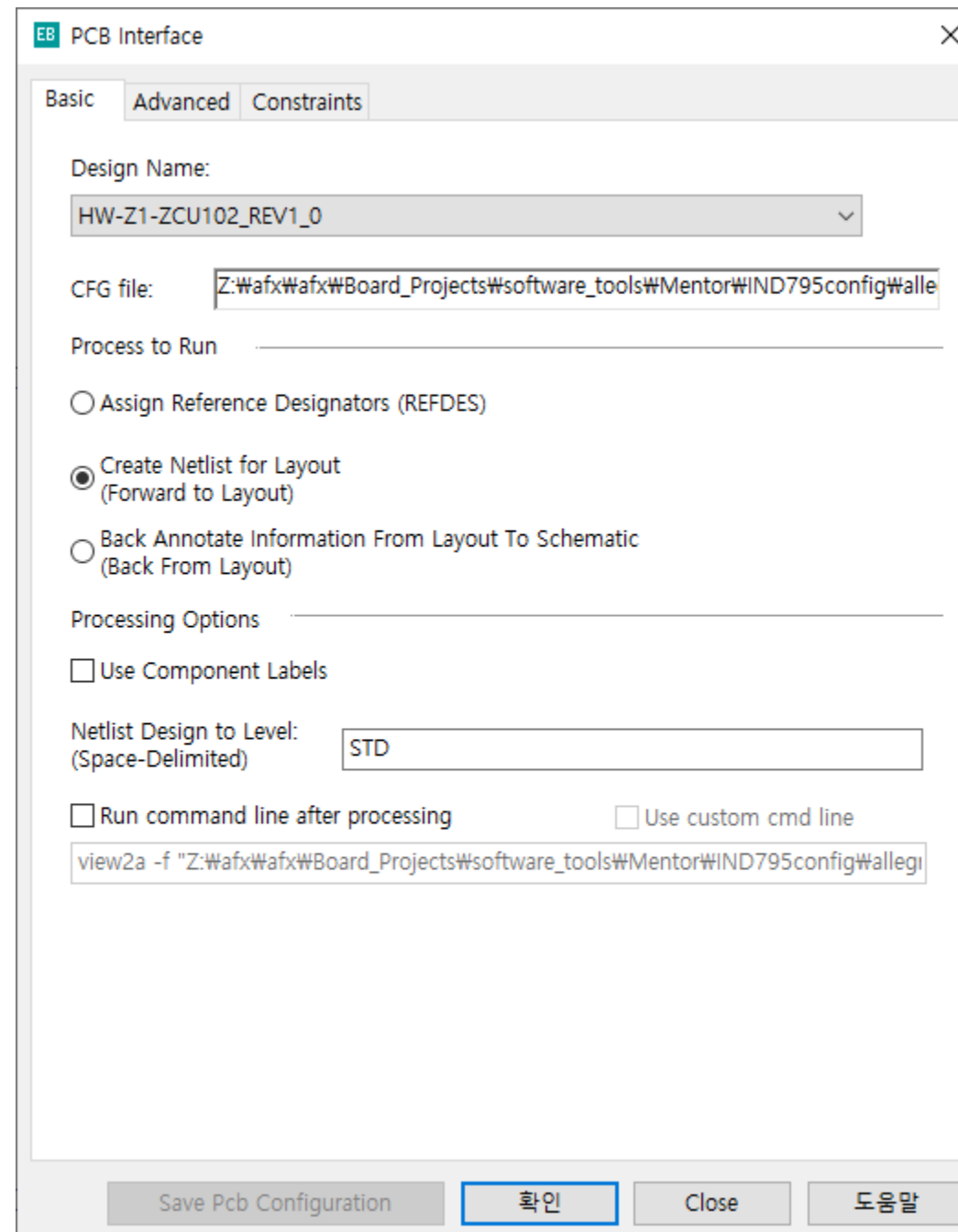

PADS Designer 특징

- PADS Designer 이점 - Project 기반의 자동저장과 자동 백업

Save 메뉴가 없고 Close시 저장되는 자동저장을 사용합니다.

Setup>Settings>Project Backup

Active	Type	Group	Number	Interval	Logs
<input checked="" type="checkbox"/>	AutoSave	User	3	4 hours	Yes
<input checked="" type="checkbox"/>	Session Startup	User	3	N/A	Yes
<input checked="" type="checkbox"/>	Session Shutdown	User	3	N/A	Yes
<input checked="" type="checkbox"/>	Application	User	3	4 hours	Yes
<input checked="" type="checkbox"/>	DxD Diagnostics	System	1	N/A	Yes
<input checked="" type="checkbox"/>	CES Diagnostics	System	1	N/A	Yes
<input checked="" type="checkbox"/>	Database Upgrade	Upgrade	2	N/A	No
<input checked="" type="checkbox"/>	Clear All Constraints	System	1	N/A	Yes
<input checked="" type="checkbox"/>	Update Reuse Block	System	1	N/A	Yes

Limit Project Backup log file size to between 100 kB and 120 kB

Enable backups

Output

```
ICDB server [info]: Starting [Autosave] backup process
ICDB server [info]: [AutoSave] backup of size [1.2 MB] created successfully in location
[C:\MGTraining\projects\Block_Library\ProjectBackup\backups\2014-01-23 13.47.28 - auto.zip]
```

Save As대신 BackUp과 Restore가 사용됩니다.

PADS Designer 특징

- PADS Designer 이점 – Stroke와 Filter, Window

마우스 가운데 버튼을 누르면 Pan
마우스 가운데 휠로 Zoom

마우스 오른쪽 버튼으로 형상을 그려주면 명령어를 사용할 수 있습니다.

- WVDelete
- HelpViewDrawHelpContents
- EditUndo
- Mirror
- WVOZoomOut
- WVOZoomIn
- WVOZoomFull
- WVOZoomArea
- AddLine
- WVOLastCommand
- HelpViewDrawHelpContents
- Rotate90

마우스 왼쪽 버튼으로 객체선택이나 메뉴

- Selection Filter

Select

Default

- Arc
- Border
- Box
- Circle
- Line
- Name
- Net and Bus
- Pin
- Property
- Ripper
- Symbol
- Text

원하는 객체를 선택하거나 해제 가능합니다.

Help

- Documentation in InfoHub...
- Error Messages
- Tip of the Day...
- Show Bindings**
- Show Strokes**
- About DxDesigner...

Sheet별로 Window를 분리해서 보는 것이 가능합니다.

PADS Designer 특징

- PADS Designer 이점 – 멀티 복사 기능
 - 부품 복사 기능
 - Net 복사 기능
 - 회로 복사 기능

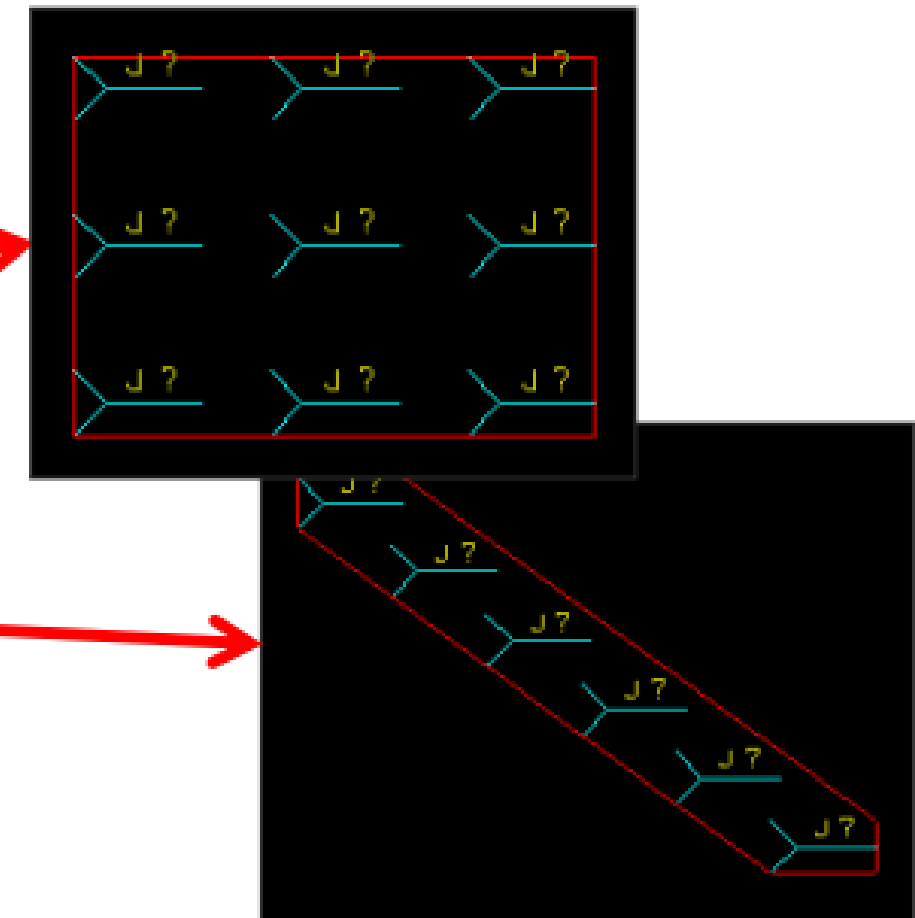
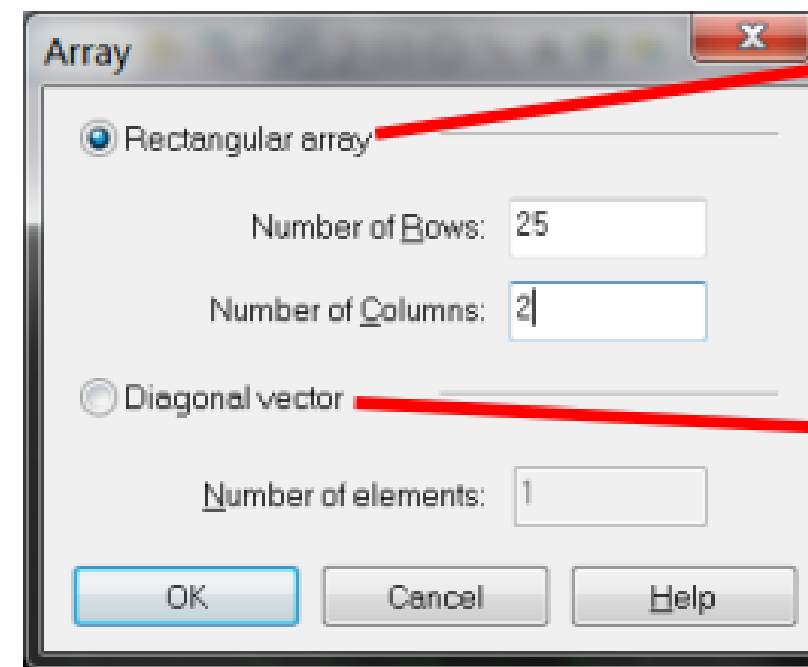
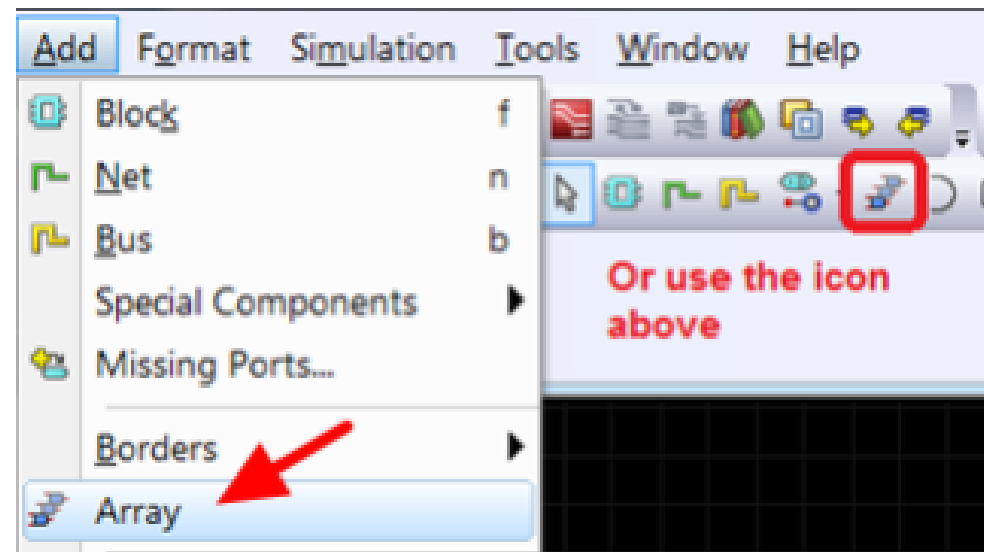

PADS Designer 특징

- PADS Designer 이점 - 버스 기능

BUS연결은 연결될 이름만 주고 Drag하면 빠르게 연결 가능합니다.

일반 연결

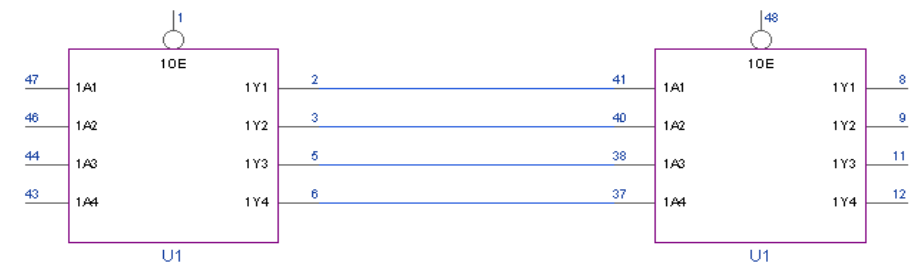

BUS 연결

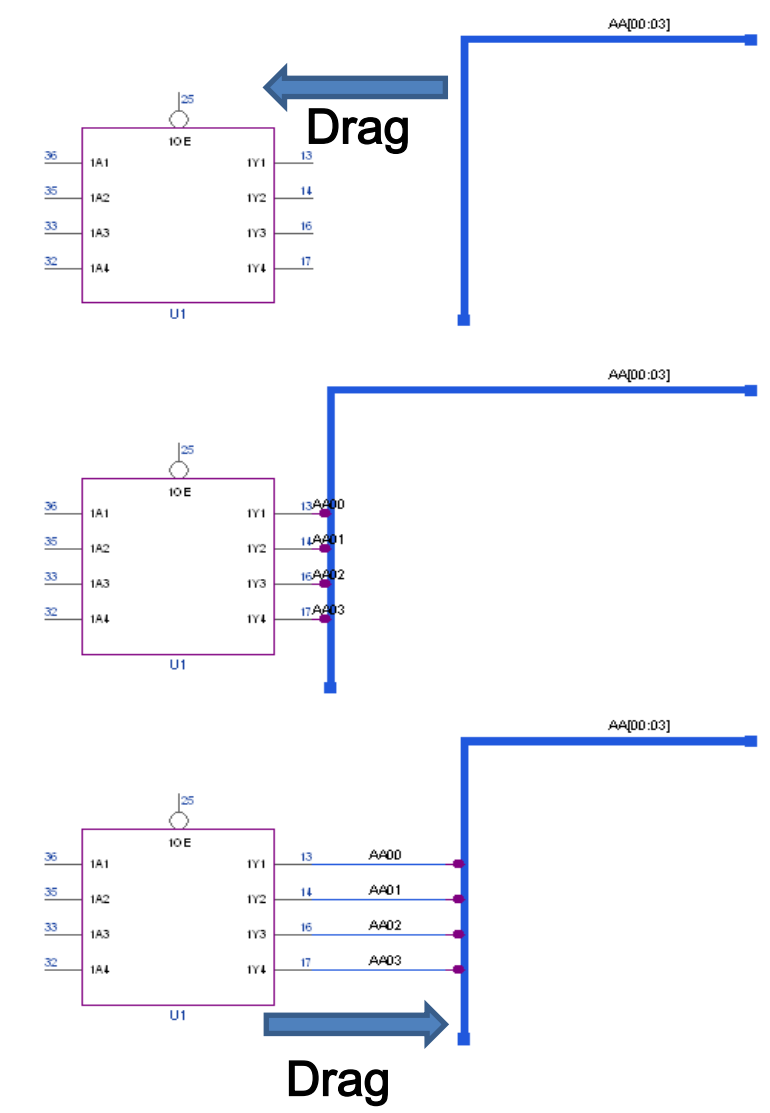
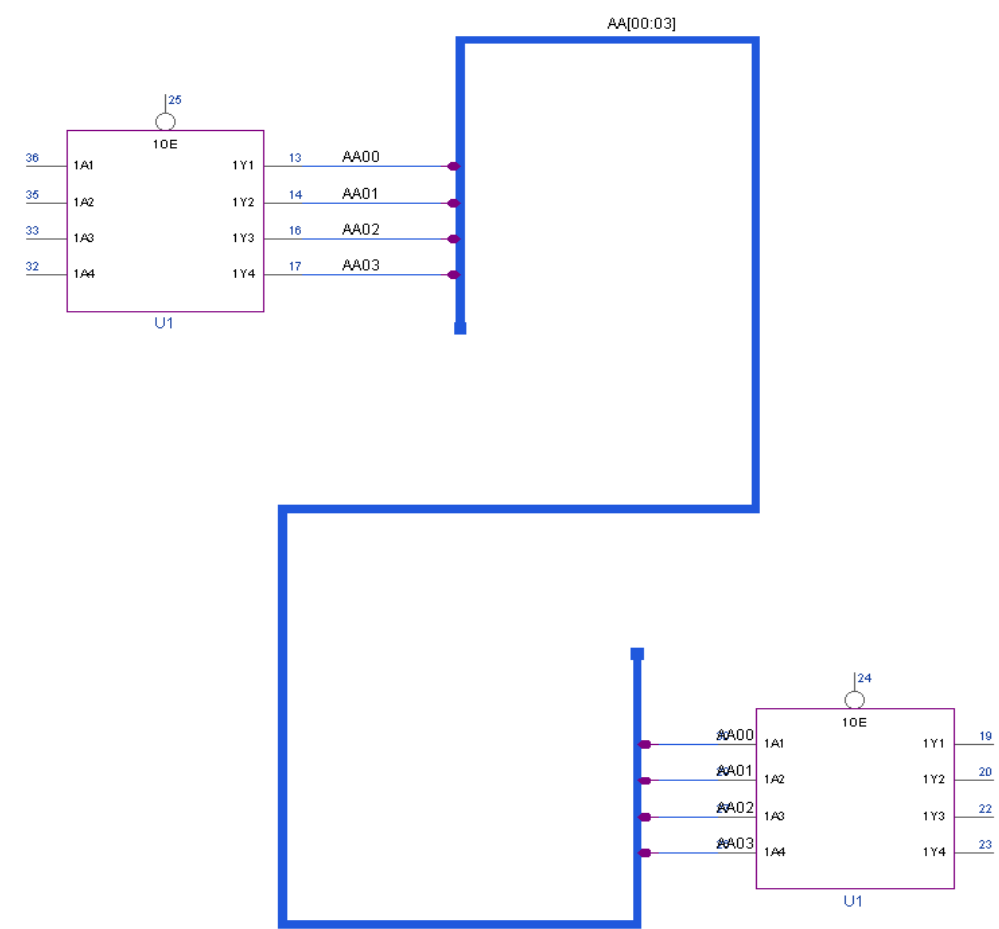

PADS Designer 특징

- PADS Designer 이점 – 여러 속성 일괄 변경

부품의 경우에 참조번호 일괄 변경

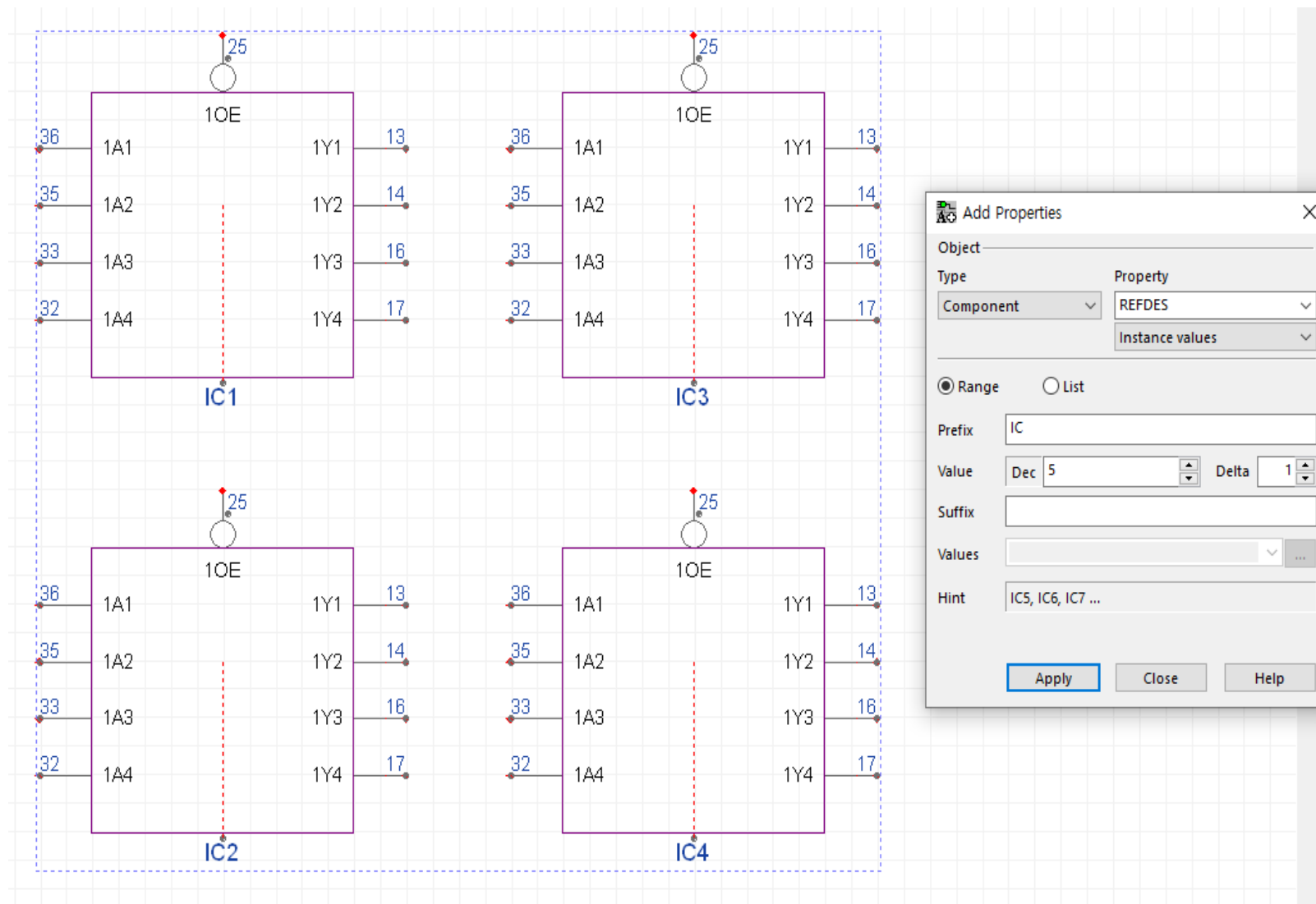

Net의 경우에 이름 일괄 변경

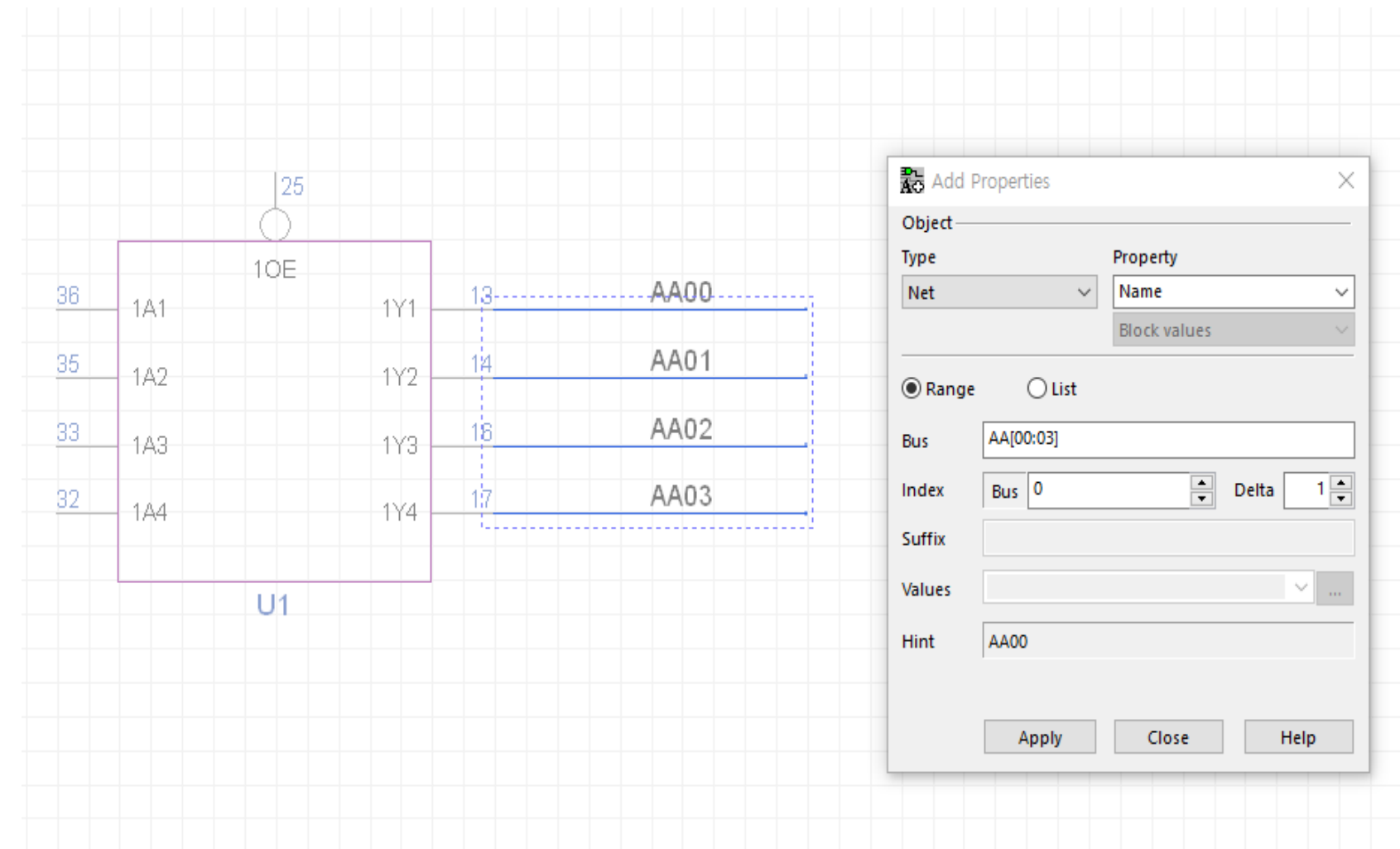

PADS Designer 특징

- PADS Designer 이점 – Block 설계

Top-Down 방식

Block 작성

Block 이름 작성

Block 형상 작성 Block에서 Net나 Bus 연결

Push로 Block 내부로 이동

Net나 Bus가 Port로 자동 연결

Block작성하면 회로도의 라이브러리에 Local Symbol로 작성됩니다.

Bottom- Up 방식

2번째에 새로운 Schematic 작성은 Block아래에 작성됩니다.

Block의 회로도를 완성하고 Port를 작성합니다.

Block 심볼을 작성하고 Size를 조정한 다음 Save합니다.

PADS Designer 특징

- PADS Designer 이점 – Net 연결 추적

부품의 경우에 연결된 Net List

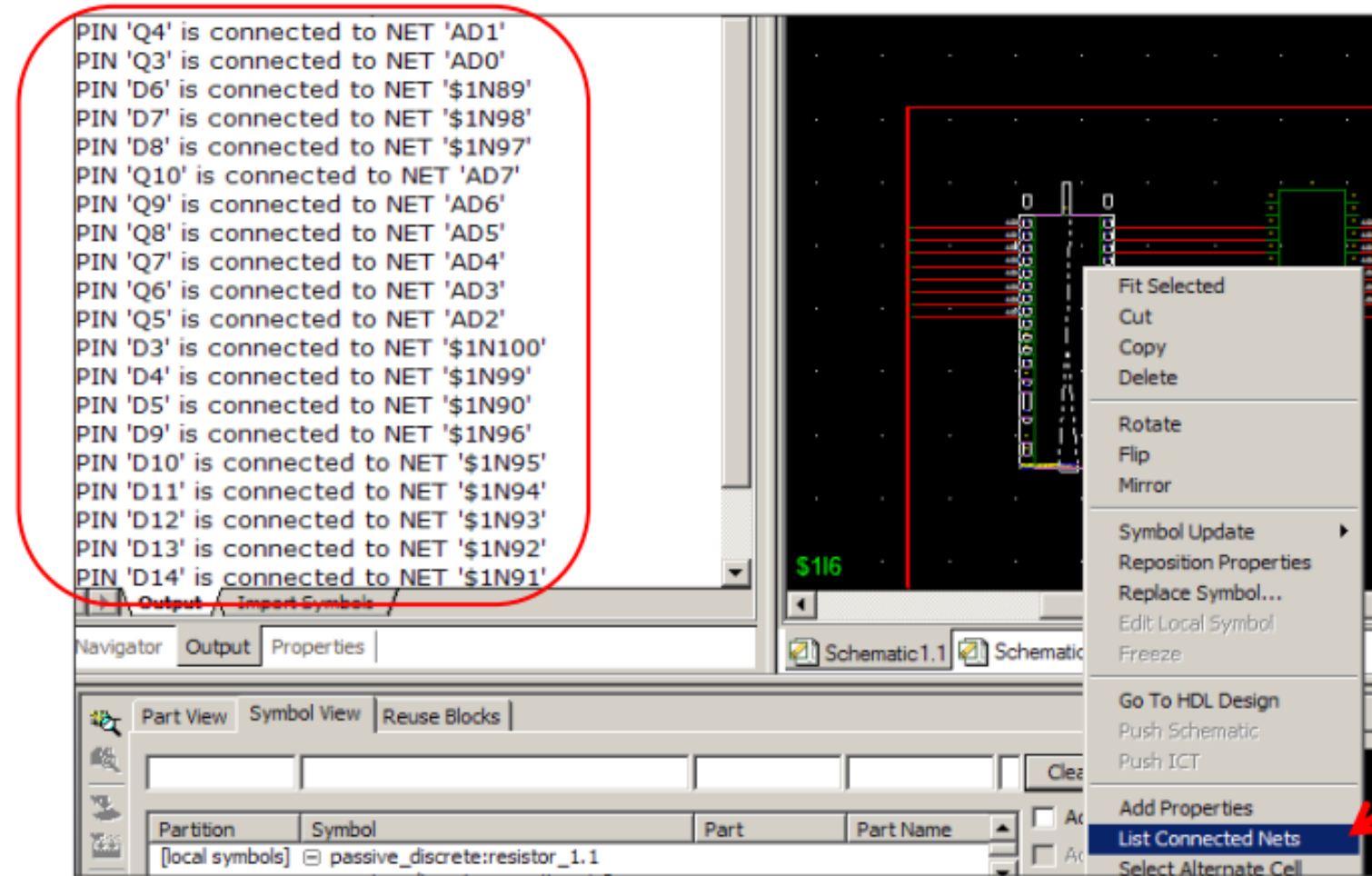

전체 연결된 Net List

File->Export->Quick Connection View

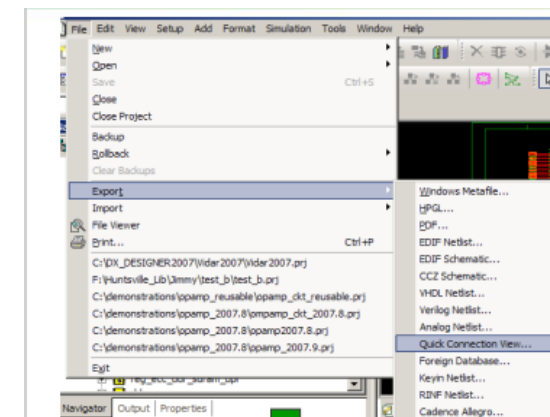

출력된 Net를 선택하면 화면의 Net 가 선택됩니다.

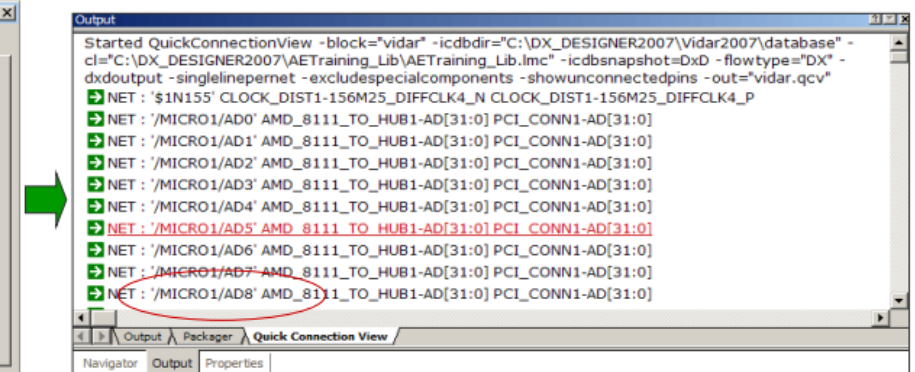
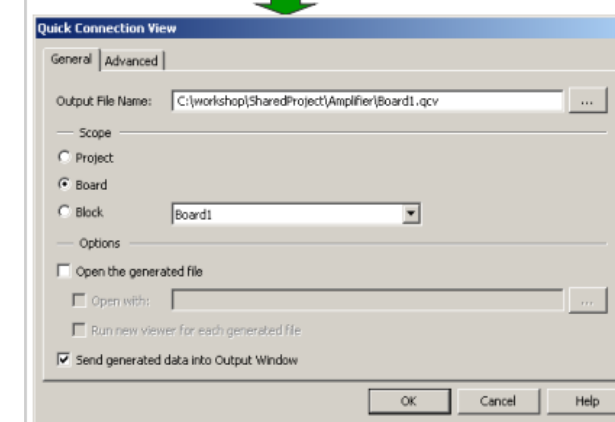

PADS Designer 특징

- PADS Designer 이점 – 회로도 Net의 Short 출력 기능

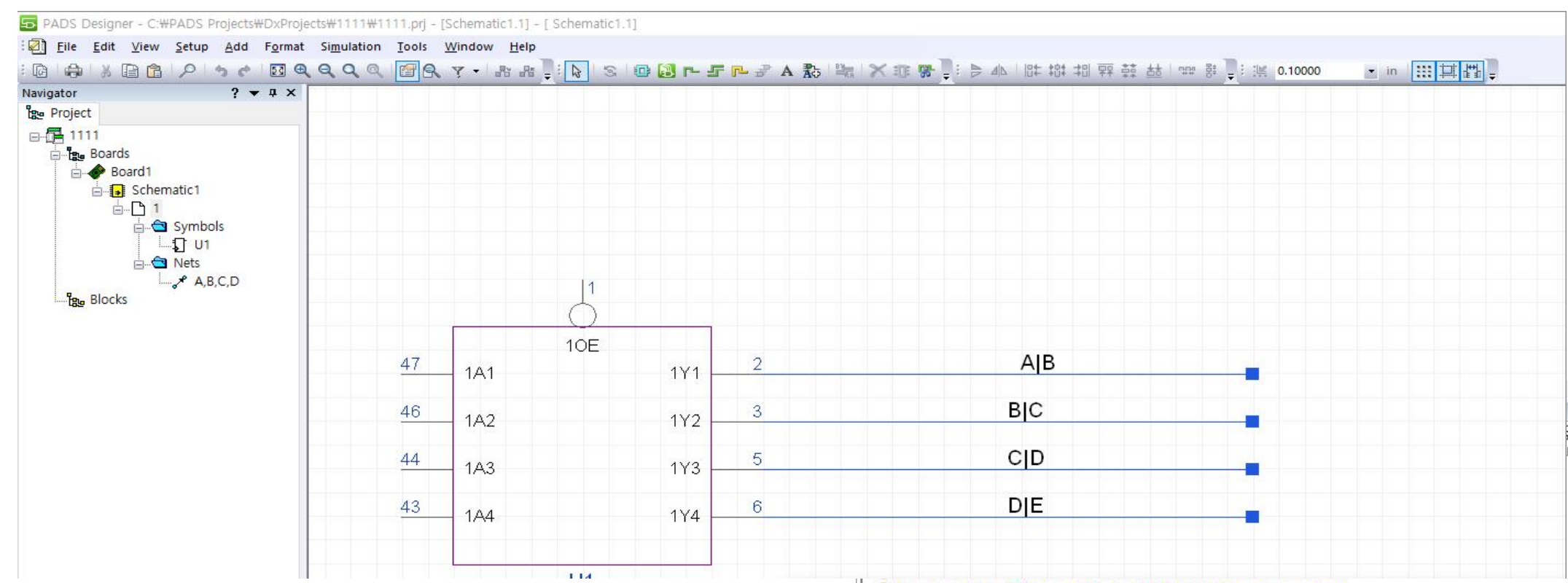

A|B
B|C
C|D
D|E

모두 A의 Net 로
출력됩니다.

Warning 6094: Schematic1 pin \$I1317.1A4 Pin not connected
 Warning 6094: Schematic1 pin \$I1317.1OE Pin not connected
 Note 5626: Summary of LogFiles/pcberr.log
 Status 0, Notes 2, Warnings 6
 Errors 0, Failures 0, Fatals 0, Internals 0
 PCB Forward Interface - V6.1; PADS Designer PADS VX.2.11 (20125186)
 c Unpublished work. Copyright 2022 Siemens

This material contains trade secrets or otherwise confidential information owned by Siemens Industry Software Inc. or its affiliates (collectively, 'SISW'), or its licensors. Access to and use of this information is strictly limited as set forth in the Customer's applicable agreements with SISW.

Initializing schematic update for design Schematic1
 Freeing schematic update data...
 REFDES completed. Check all open schematics for updates...

Finished C:\MentorGraphics\PADSVX.2.11\SDD_HOME\common\win32\bin\pcbui.exe

```
Schematic1.asc - Windows 메모장
파일(F) 편집(E) 서식(O) 보기(V) 도움말(H)
!PADS-POWERPCB-V10.0-MILS!

*PART*
U1 74AC16244DLR@SOP50P810X120-48N
*CONNECTION*
*SIGNAL* GND
U1.45 U1.4
U1.4 U1.39
U1.39 U1.34
U1.34 U1.28
U1.28 U1.21
U1.21 U1.15
U1.15 U1.10
*SIGNAL* VDD
U1.7 U1.42
U1.42 U1.31
U1.31 U1.18
*SIGNAL* A
U1.2 U1.3
U1.3 U1.5
U1.5 U1.6
```

PADS Designer 특징

- PADS Designer 이점 – Import와 Export

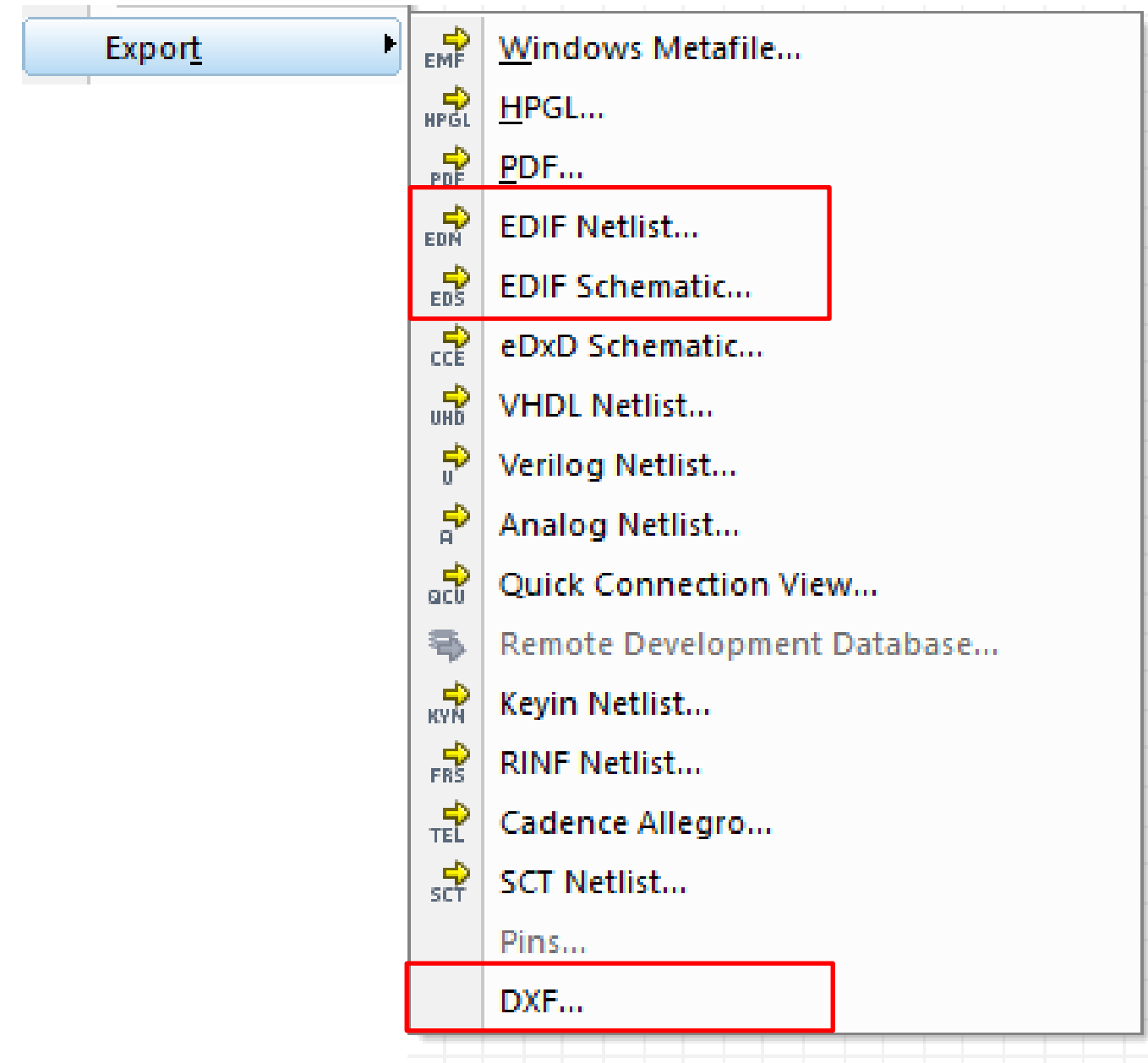
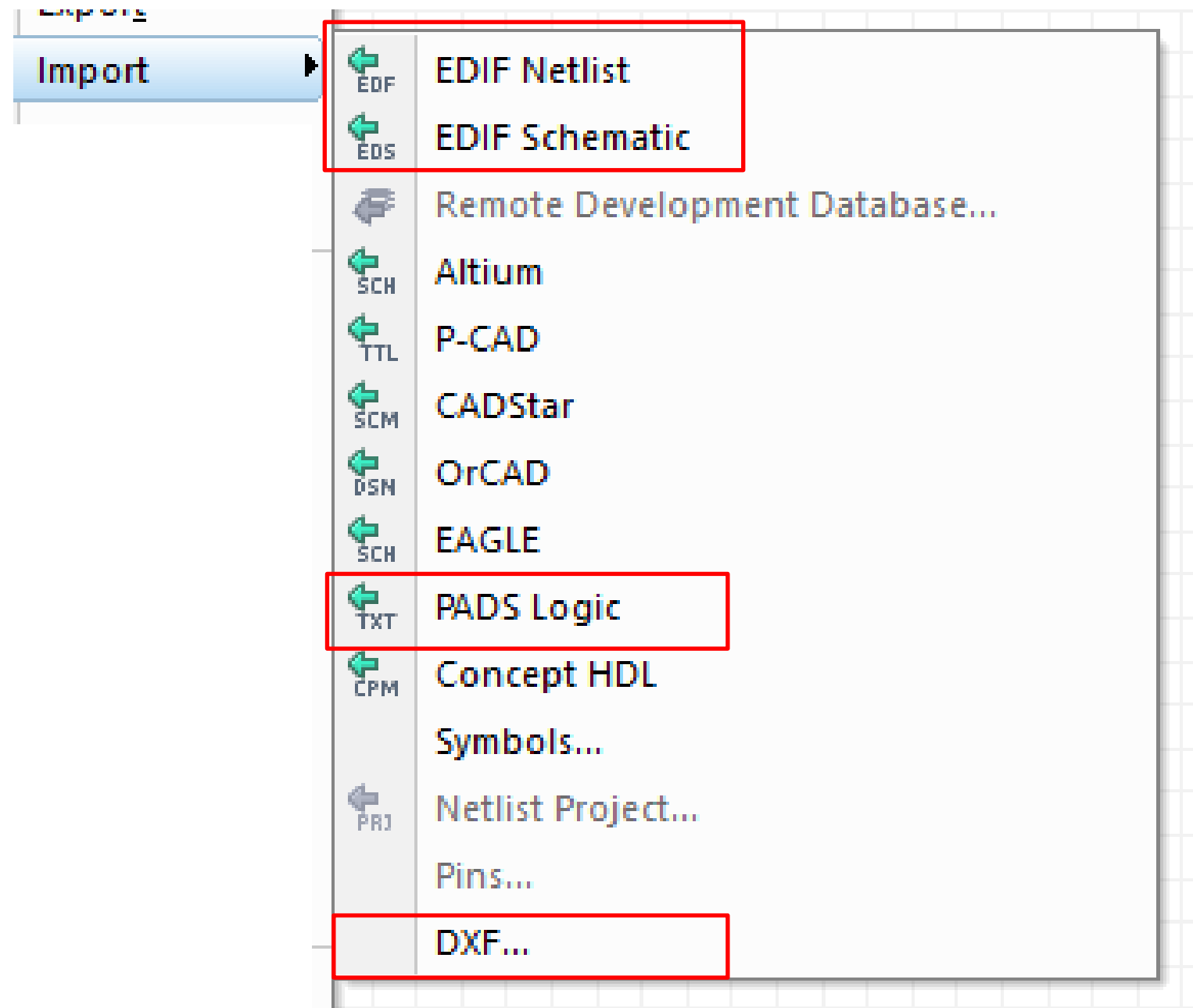

PADS Designer 특징

- PADS Designer 이점 – Variant 기능

하나의 회로도로 다양한 옵션부품을 관리 할 수 있습니다.

USA의 회로도는 C0가 빠진 BOM과 PCB부품도면 출력이 가능합니다.

Variant Definition

Name	Number	Description
USA	U001	USA West
EU	E002	EU East

Group Definitions:

Group Name	Group Description
(Default)	(Default)
G7	Description for New_Group

Group variant assignment

Available	Assigned
	USA
	EU

Variant Manager

Ref Des	Part Number	USA	EU
C0	C0603-1R2-100-025	Unplaced	
U1	74AC16244DLR		
U2	74AC16244DLR		

PADS Designer 활용

- PADS Designer 확장 – 중앙라이브러리 구축
- DataBook – Database와 ECAD라이브러리의 연결

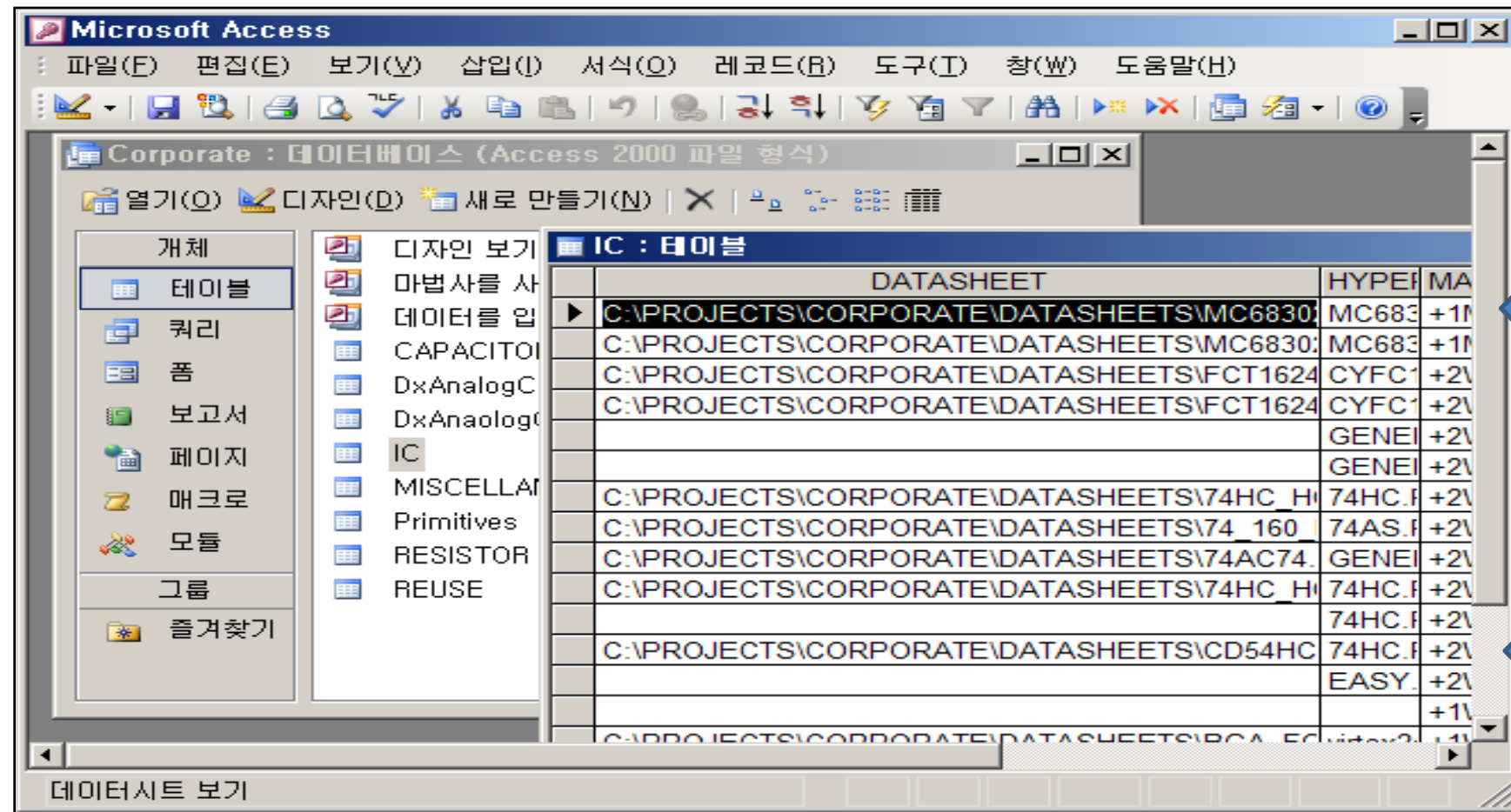

1개의 행이 부품 1개

연결
각 열이 부품의 속성들

연결

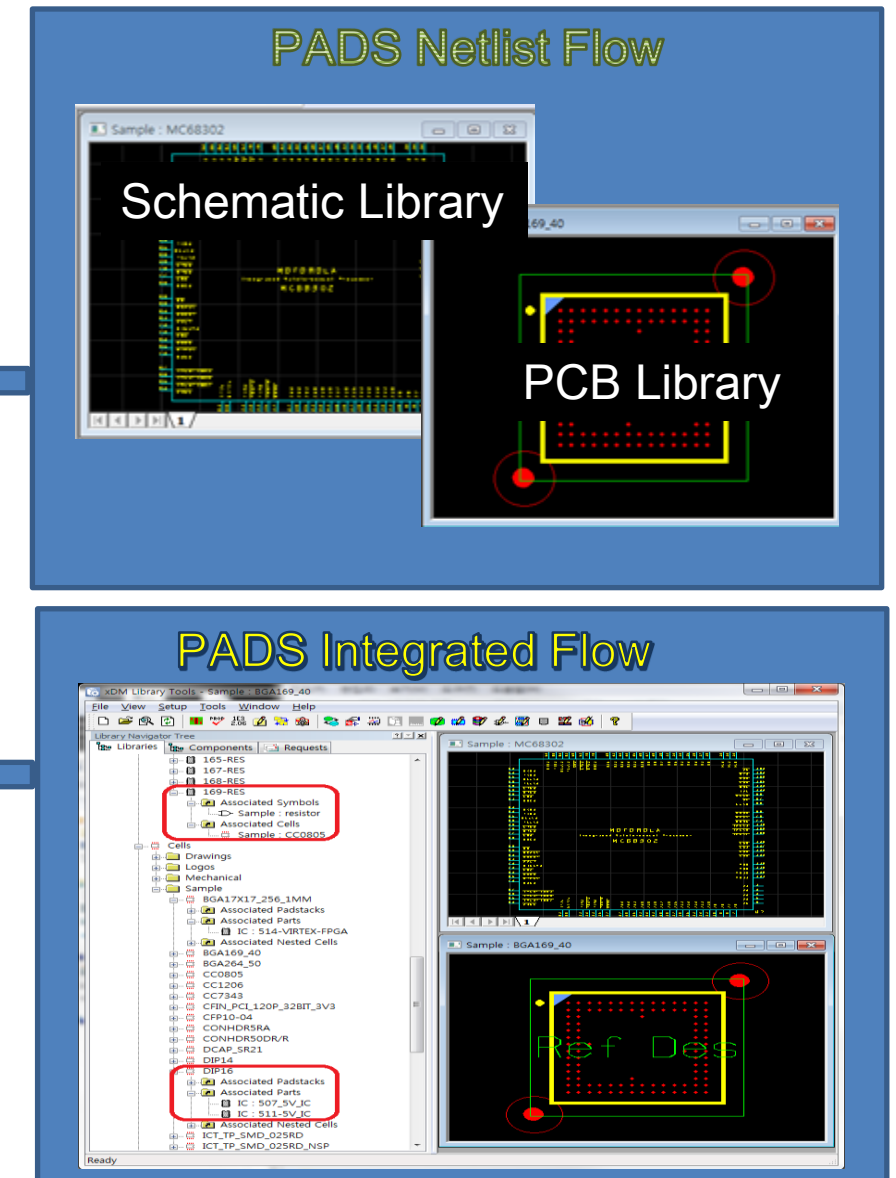

PADS Designer 활용

- PADS Designer 확장 – 중앙라이브러리 구축
- DataBook – Database와 ECAD라이브러리의 연결

The screenshot shows the PADS Designer interface with a Microsoft Access database window open. The database table 'IC : 테이블' lists various ICs with columns for DATASHEET, HYPEF, and MA. A component 'U2' is placed on a PCB grid, showing its pin connections (10OE, 1A1-1A4, 1Y1-1Y4) and pin numbers (41-48, 8-12). A Properties window on the right shows details for the component, including its ID (\$11841), Symbol Name (TI_74AC16244DLR.1), and various attributes like REFDES (U2) and SIGNAL (GND:4, 10, 15, 21, 28, 34, 39, 45).

Database와 연결

Part Number	Manufacturer	ManufacturerPN	Description
74AC16244DLR	TI_74AC16244DLR	TSSO12X8-G48X3	Logic - Buffers, Dri...
74FCT16244	74FCT16244	digkey	800-1588-2-ND
74HC160PW	74HC160PW		Logic - Counters, ...
AT91SAM7X512-A...	AT91SAM7X512-AU	QFP40P1400X140...	NXP Semiconduct...
BU45U69G2TR	BU45U69G2-TR		Atmel
CD74HC192NSR	TL_CD74HC192NSR	NS16	Logic - Counters, ...
CY62128EV30LL	CY62128EV30LL	SOIC-32	Memory
FIN1027M	FIN1027M	SOIC-8	Avnet Express
FIN1028M	FIN1028M	SOIC-8	Avnet Express
FSA2257MUX	FSA2257MUX		Fairchild Semicon...
ICL7106CPL+	ICL7106CPL+		Maxim Integrated
LM3552SD	TL_LM3552SD		Texas Instruments
LM6132	TL_LM6132BIM		Texas Instruments
LMR62014	TL_LMR62014		Texas Instruments
LMV7271MF	TL_LMV7271MF		Texas Instruments
M74HC174B1R	ST_M74HC174B1R		STMicroelectronics
MC145421	MC145421	SOIC-24	Obsolete
MC1488N	TL_MC1488_INV.TL...		Texas Instruments
MC33269DT-3.3G	MC33269DT-3R3	TO-252-3	OnSemi
MC33269DT-5.0G	MC33269DT-5R0	TO-252-3	OnSemi
MC68302EH20C	MC68302	digkey	MC68302EH20C...
MC74HC74AN	DIGIKEY MC74HC...	ON MC74HC74	PDIP-14

Database의 값이 속성으로 연결됨

Database와 연결하지 않으면 속성을 라이브러리마다 입력해야 합니다.

PADS Designer 활용

- PADS Designer 확장 – 중앙라이브러리 구축
- DataBook – Database와 속성 검증 기능

부품이 Database와 다른 경우는 부품의 속성을 임의로 변경했거나, Database의 값이 편집 혹은 삭제될 수 있습니다.

부품 Database의 정보는 항상 같을 수 많은 없기 때문에, 회로를 작성하고 나서, 마지막에는 원본과 Database가 맞는지 검증 필요합니다.

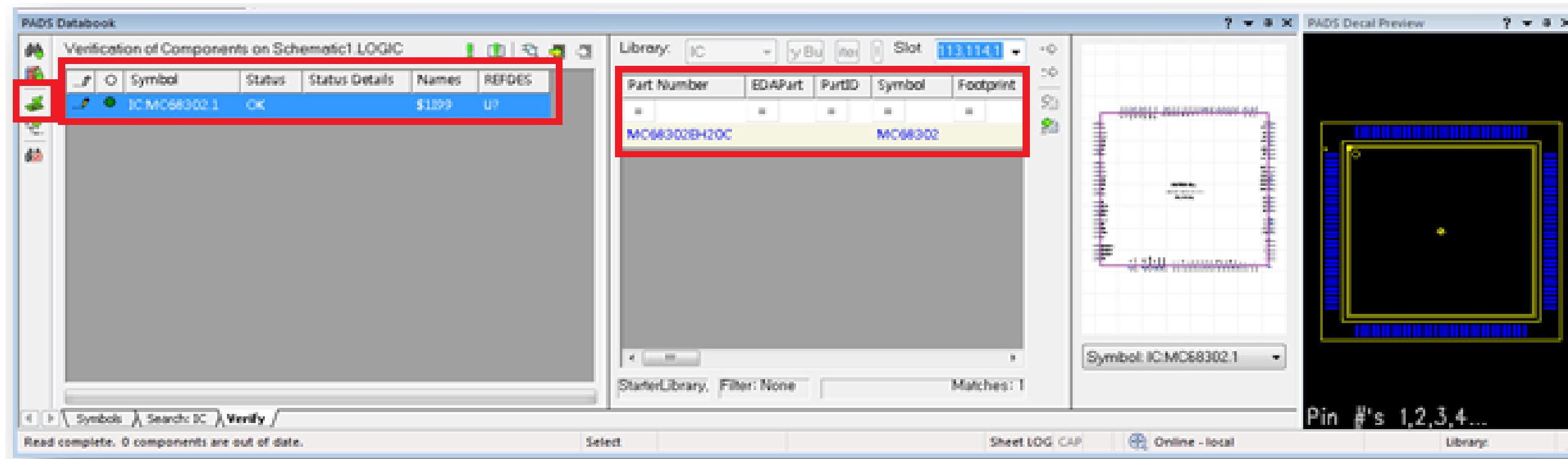

PADS Designer 활용

- PADS Designer 확장 – 중앙라이브러리 구축
- DataBook – Database와 속성 검증 기능

노란색은 Value에 Database 에는 값이 있는데 회로엔 없는 경우

초록색은 Database 와 회로의 속성이 완전히 일치하는 경우

빨간색은 Database 와 회로의 속성값이 다른 경우

Symbol	Status	Status Details	Names	Rx
Capacitor:Capacitor.1	Missing Properties	Value	\$1132	C1
Capacitor:Capacitor.1	OK		\$1111,\$111	C1
Capacitor:Capacitor.1	Zero Matches		\$1122	C1

PADS Designer 활용

- PADS Designer 확장 – 중앙라이브러리 구축
- DataBook – Database와 속성 검증 기능

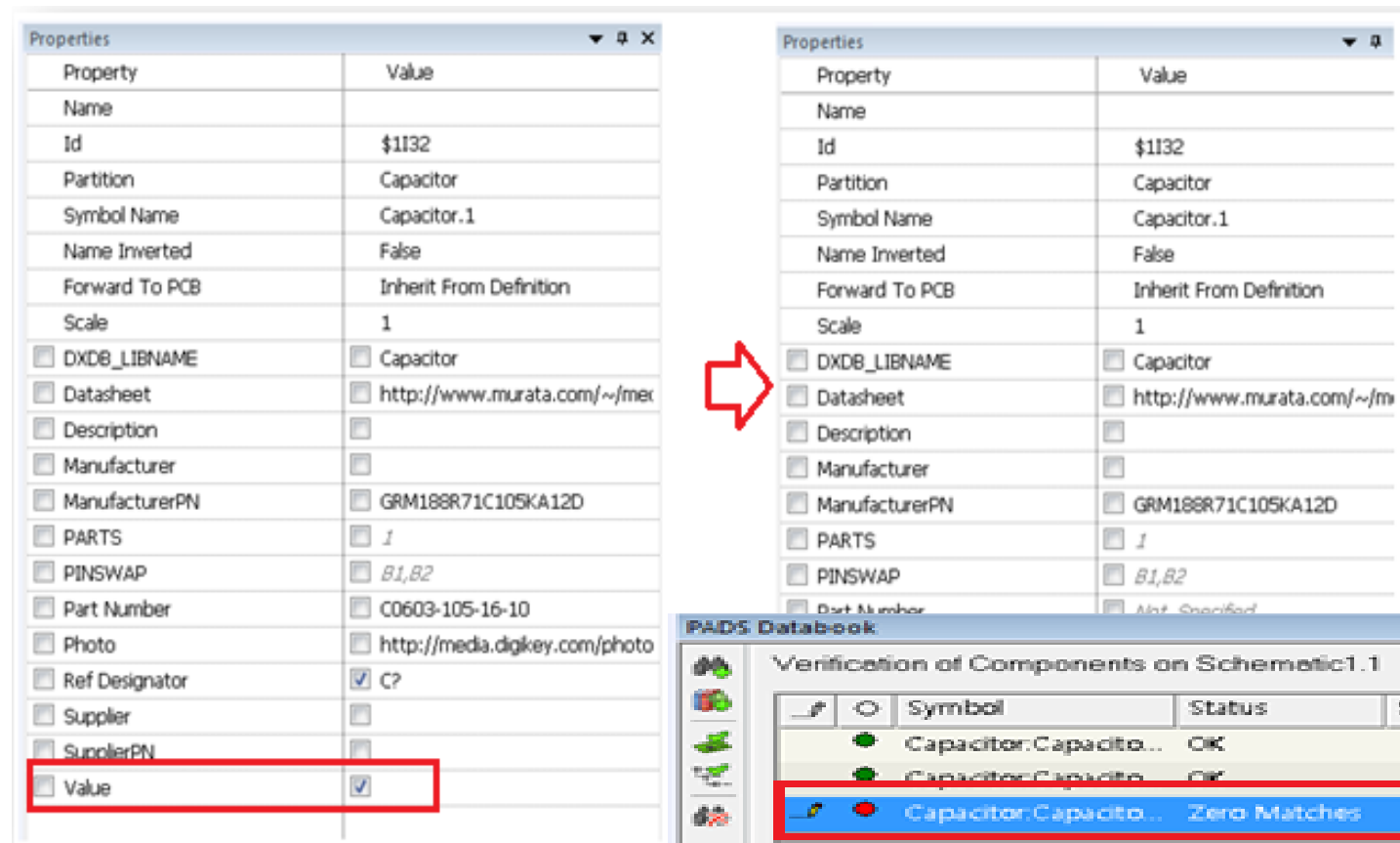

검색된 부품을 선택하고 다음에 Annotate Component All Properties를 하면 회로에 누락된 부분이 반영되고 초록색으로 변경됩니다.

전체가 초록색이면 Database=회로도=BOM으로 관리 가능합니다.

PADS Designer 활용

- PADS Designer 확장 - 해석 기능확장
SPICE 시뮬레이션 - AMS

회로도작성, 전원소스, 모델 지정 Parameter작성

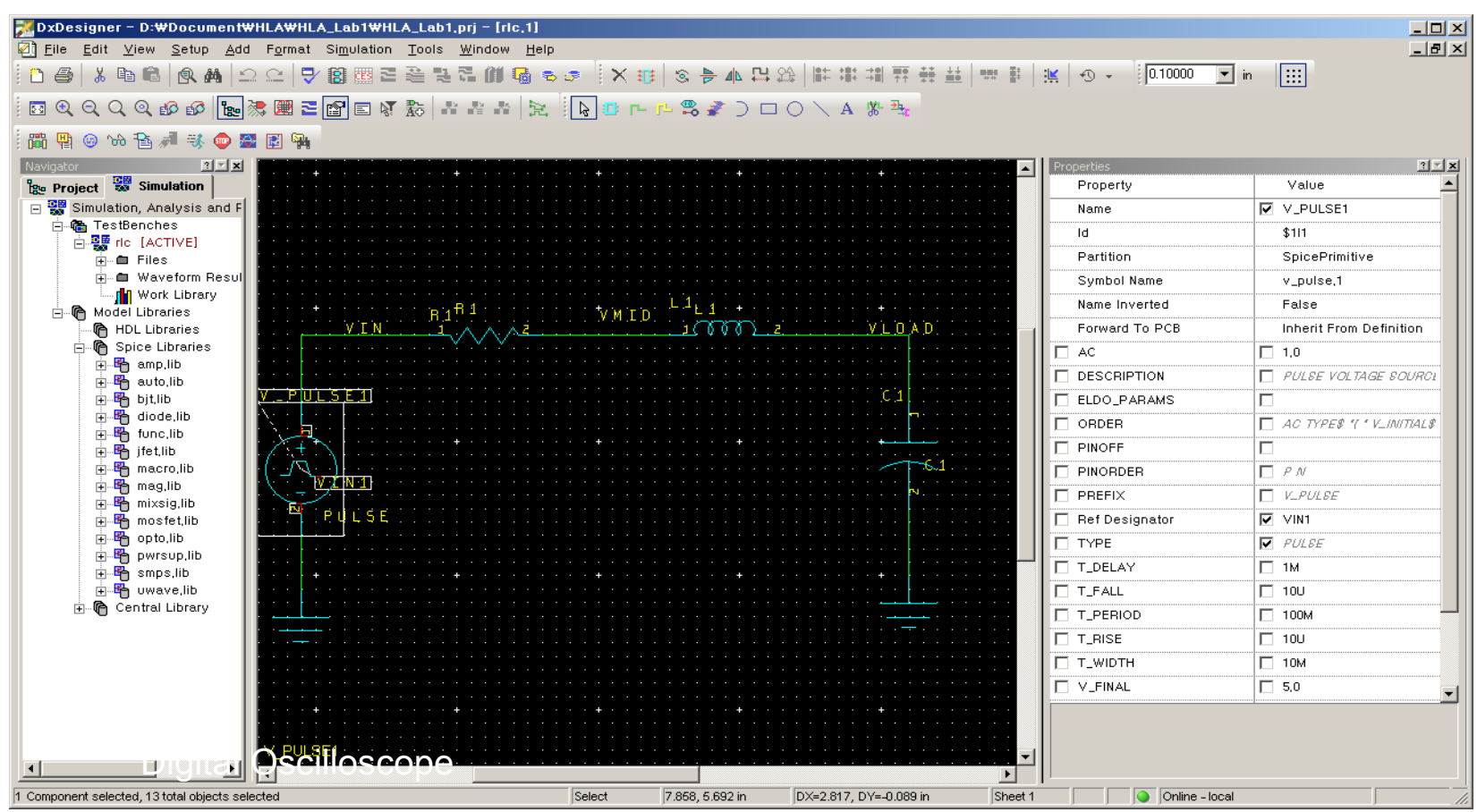

- DC analysis
- frequency analysis
- time-domain analysis
- Parametric sweeps analysis
- Monte Carlo analysis

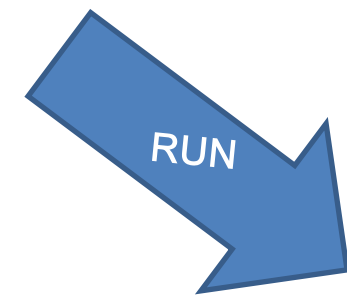

파형확인, 측정, Waveform 계산

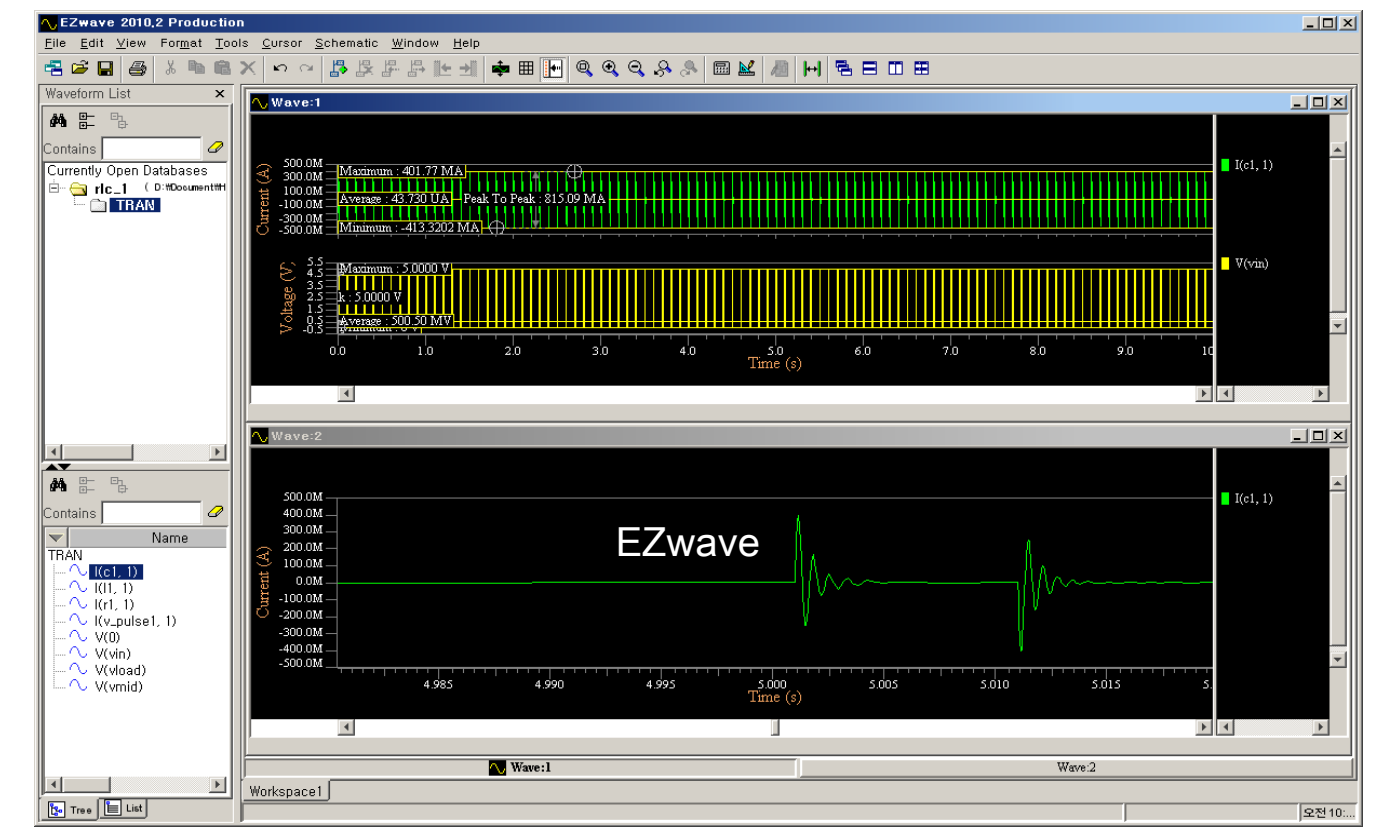

PADS Designer 활용

- PADS Designer 확장 - 해석 기능확장
IBIS 전송선로 시뮬레이션 - HyperLynx SI

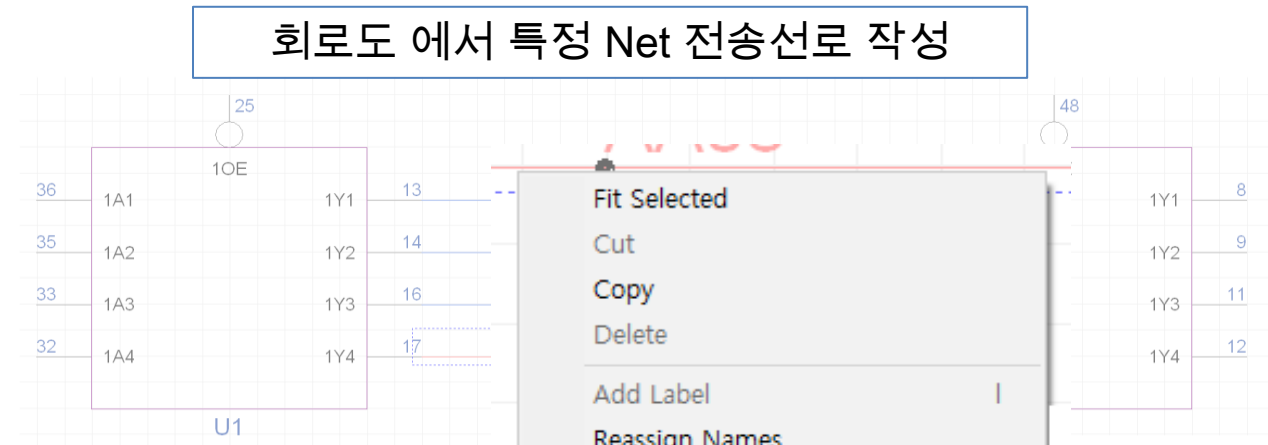

- Fit Selected
- Cut
- Copy
- Delete
- Add Label
- Reassign Names
- Add Properties
- Disconnect
- Select Net
- Select Net Branch
- HyperLynx LineSim**
- Propagate Net Name To Pin
- Combine crossing Nets
- Load into Search
- Properties

전송선로 작성 (PCB 디자인 전 해석)

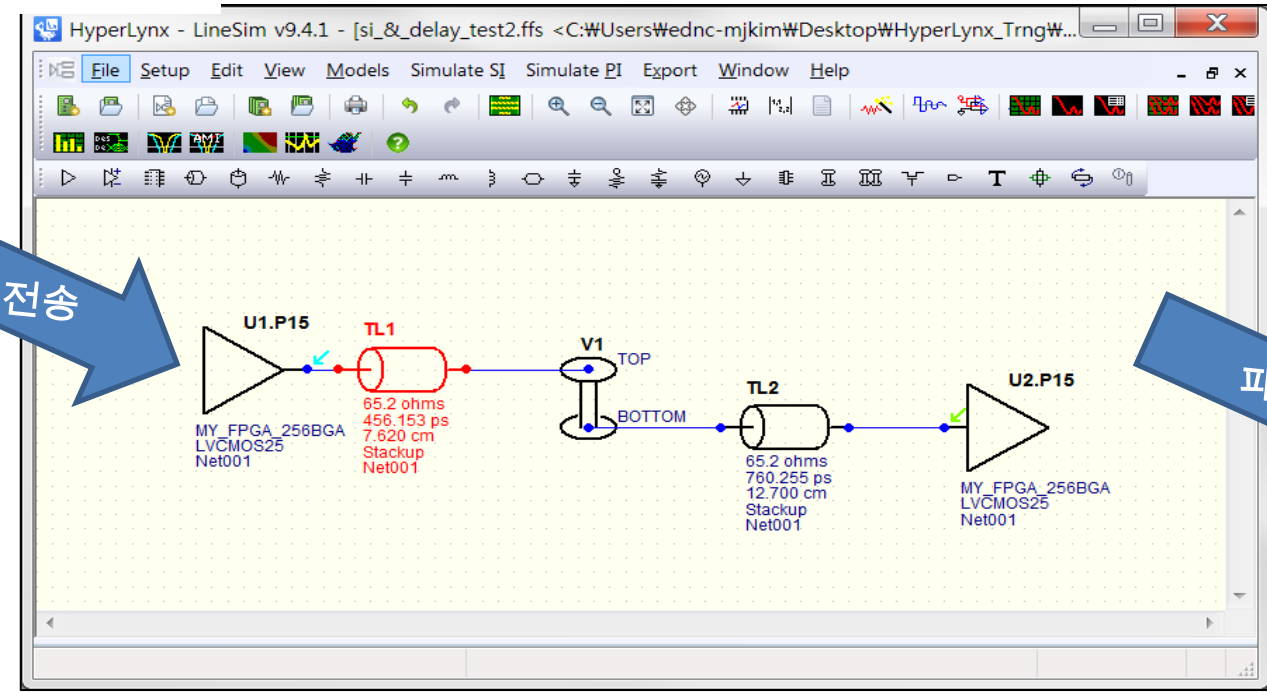

파형확인

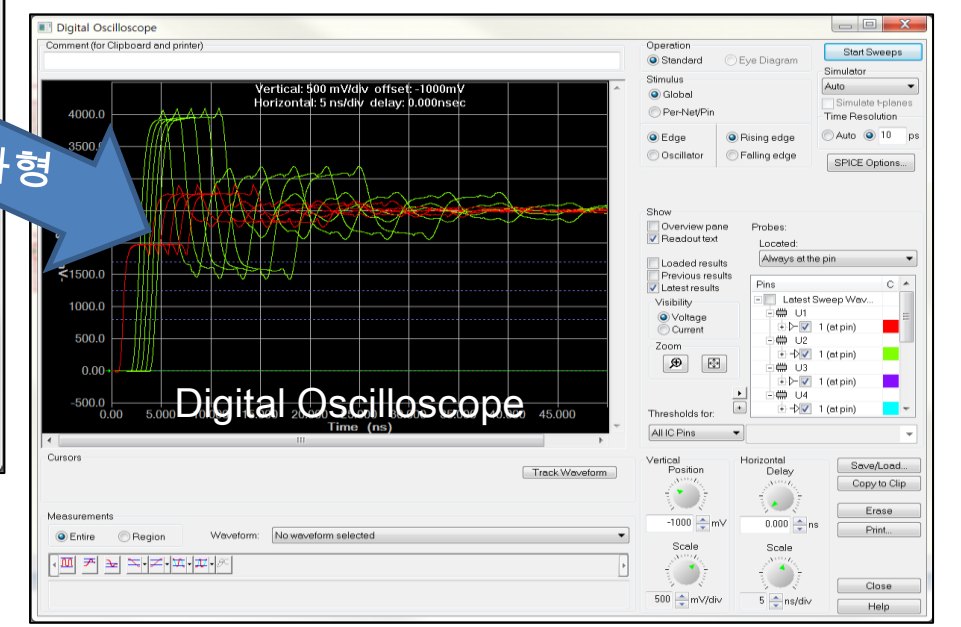

PADS Designer 활용

- PADS Designer 확장 - 내부 커스텀 기능
 - PADS Designer 기본 기능에 없는 기능을 Script로 작성해 구현합니다.
 - PADS Designer에서 가능한 Language는 JScript와 VBScript 가능합니다.

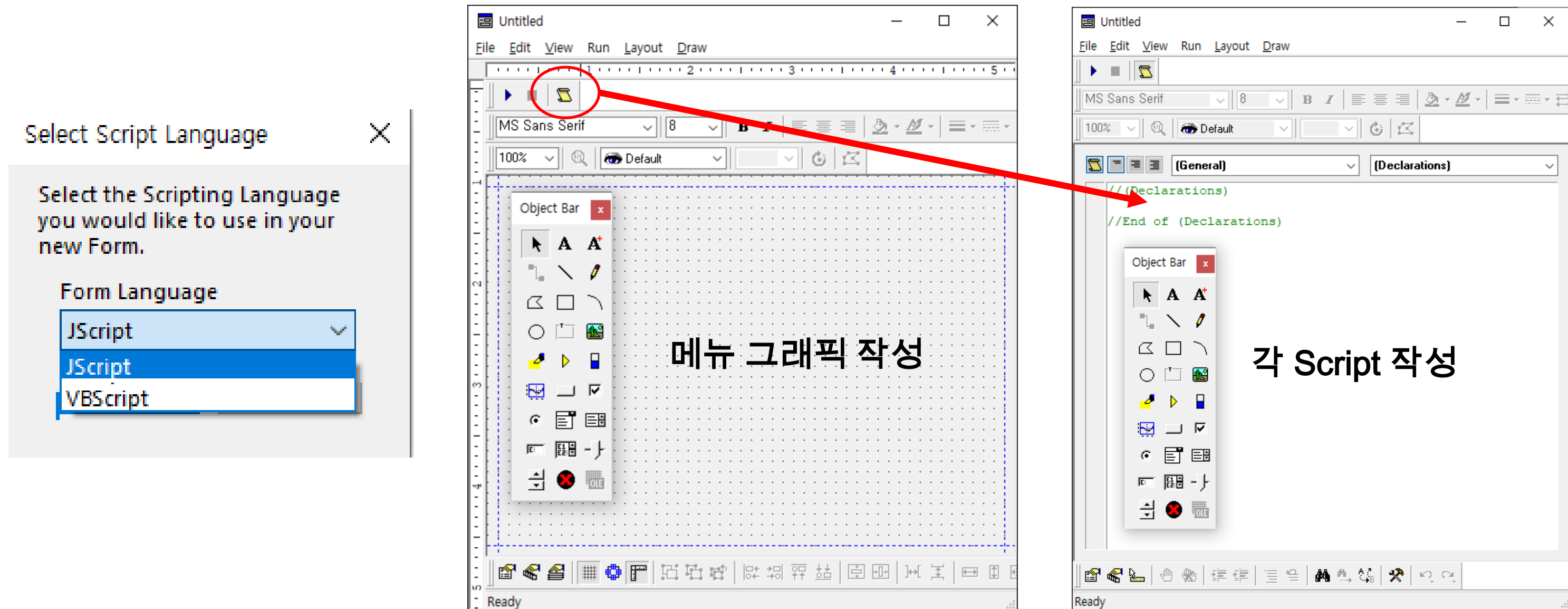

PADS Designer 활용

- PADS Designer 확장 - 내부 커스텀 기능
 - 스트립트 작성후에 아래와 같이 메뉴로도 구현 가능합니다.

PADS Intergrated Flow

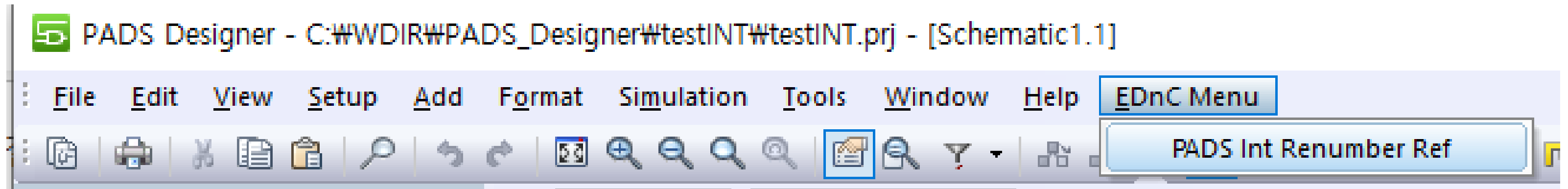

PADS Netlist Flow

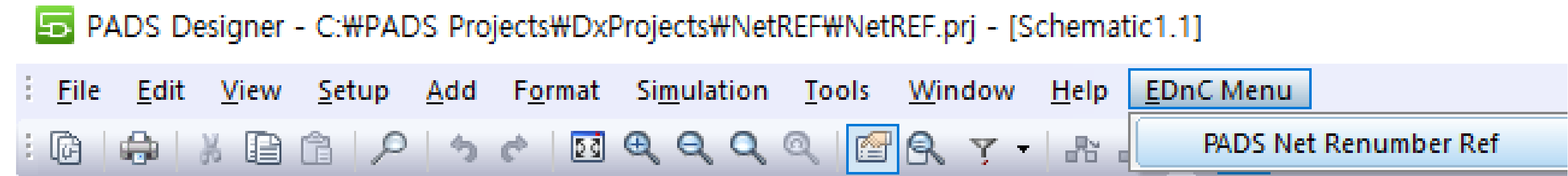

PADS Designer 활용

- PADS Designer 확장 - 내부 커스텀 기능
 - 스트립트 작성을 위한 참고파일 - 설치파일 dxdesigner_auto.pdf

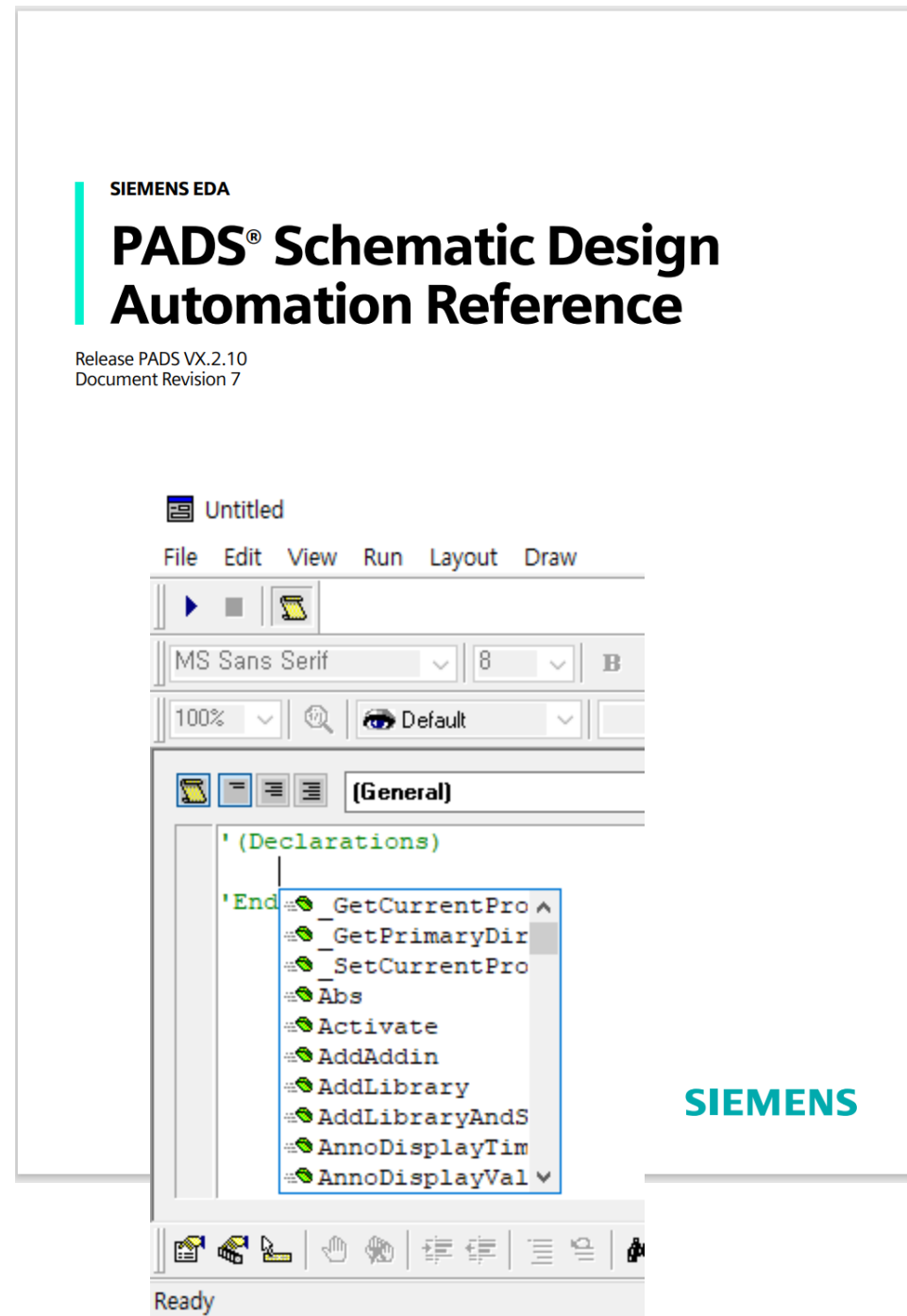

Table of Contents

Revision History ISO-26262

Chapter 1	
Automation and Scripting	21
Automating Tasks through Scripting	21
Before You Begin	22
Compatible Scripting Languages	25
Running Scripts	26
Search Order for Scripts	26
The scripts.ini File	27
Debugging Scripts	29
Invalid Objects in Scripts	29
Specifying Script and Form Execution	31
Execution at Application Startup	31
Executing a Script or Form at Application Startup	31
Execution from the OS Command Window	32
Running a Script from the Command Line	32
Running a Form from the Command Line	32
Advantages of Using Forms	33
Key Binding	34
Key Binding Definition File	35
Chapter 2	
Examples of Xpedition Designer Automation	37
Script Examples in this Document	37
Example 1: Create/Add Menus	37
Example 2: Opening a Datasheet	40
Example 3: Using Objects in Scripts	42
Example 4: Using Applications and Documents in Scripts	49
Chapter 3	
Schematic Editor Data Objects	55
AddInfo Object	57
InitiallyDisabled Property (AddInfo Object)	58
InitiallyVisible Property (AddInfo Object)	59
LicenseFeature Property (AddInfo Object)	60
Name Property (AddInfo Object)	61
Placement Property (AddInfo Object)	62
ProgId Property (AddInfo Object)	63
RuntimeCreateDecision Property (AddInfo Object)	64
ShortCutKey Property (AddInfo Object)	65
ToolBarButton Property (AddInfo Object)	66

PADS® Schematic Design Automation Reference, PADS VX.2.10 5

Xpedition Designer Schematic Editor Enumerated Types
VdObjectType Enum

VdObjectType Enum

Scope: Xpedition Designer schematic editor
Prerequisites: None.
Specifies an object type.

Usage

VdObjectType.Constant

Arguments

- VDTL_ANNOTATION
Annotation layer. The numerical value for this constant is 1036 (&H40C).
- VDTL_BACKGROUND
Background layer. The numerical value for this constant is 1038 (&H40E).
- VDTL_BORDER
Border layer. The numerical value for this constant is 1040 (&H410).
- VDTL_HIGHLIGHT
Highlight layer. The numerical value for this constant is 1041 (&H411).
- VDTL_SELECTION
Selection layer. The numerical value for this constant is 1037 (&H40D).
- VDTL_VALUE
Point. The numerical value for this constant is 1039 (&H40F).
- VDTS_ARC
Arc. The numerical value for this constant is 4.
- VDTS_ATTRIBUTE
Attribute. The numerical value for this constant is 6.
- VDTS_BLOCK
Block. The numerical value for this constant is 11.
- VDTS_BOX
Box. The numerical value for this constant is 1.
- VDTS_CIRCLE
Circle. The numerical value for this constant is 3.
- VDTS_COMPONENT
Component. The numerical value for this constant is 7.

PADS® Schematic Design Automation Reference, PADS VX.2.10 677

Note - Viewing PDF files within a web browser causes some links not to function. Use HTML for full navigation.

PADS Designer 활용

- PADS Designer 확장 – 내부 커스텀 기능 : Reference Renumber 기능 스크립트

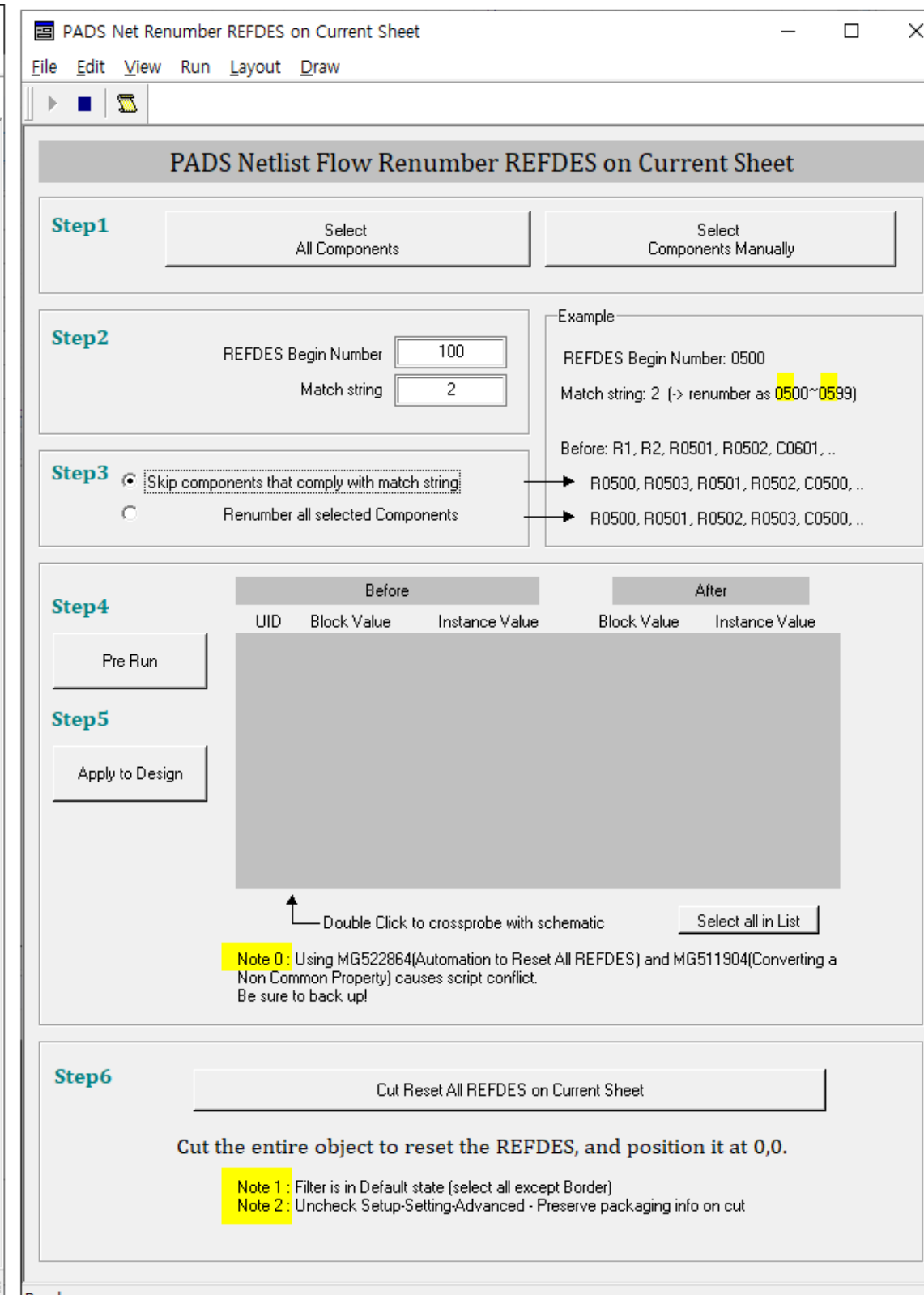
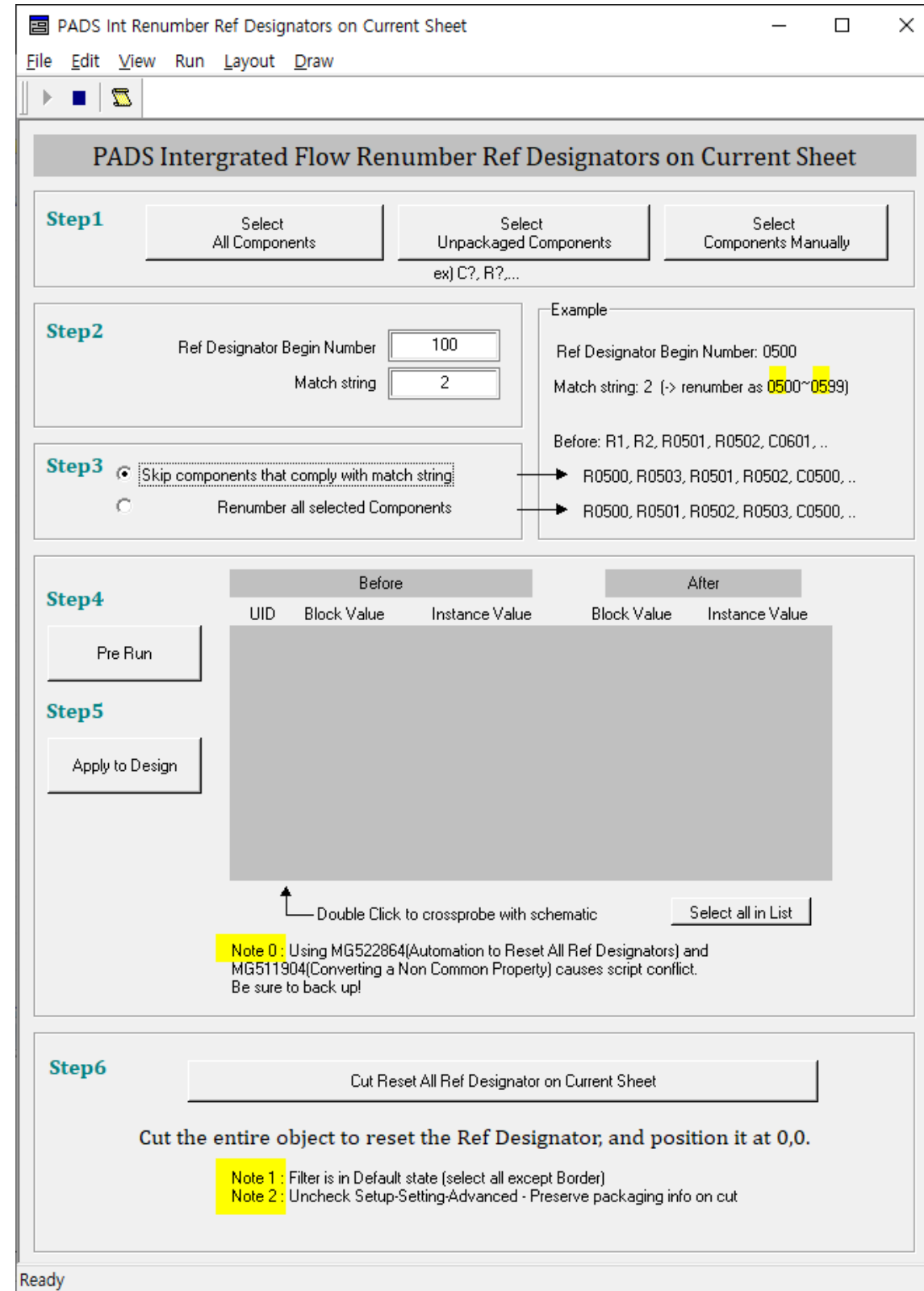

PADS Designer 활용

- PADS Designer 확장 – 내부 커스텀 기능 : 메뉴추가
 - 이 스크립트는 PADS Designer GUI에 메뉴 추가를 보여주는 기본적인 예시입니다.

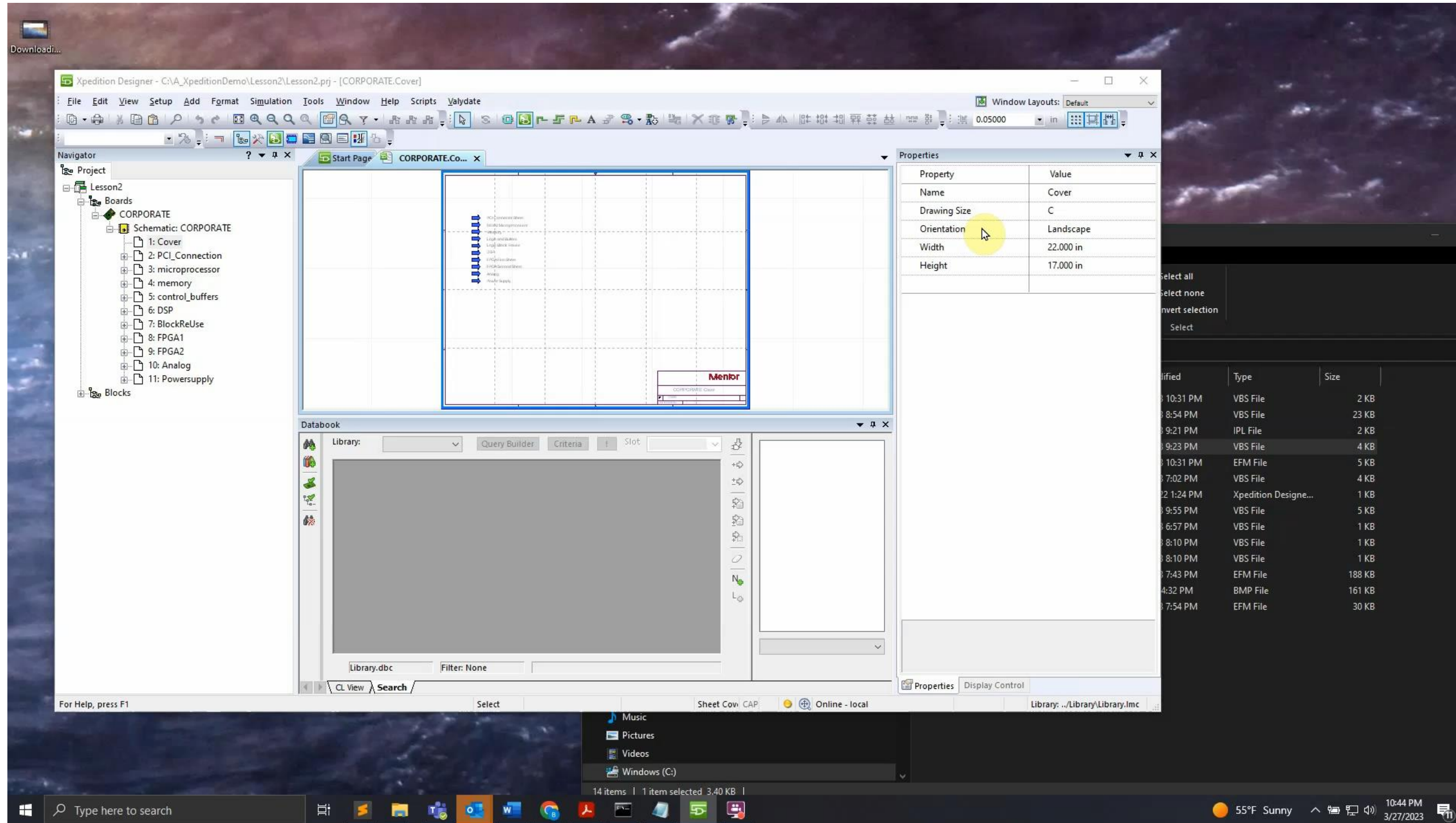

PADS Designer 활용

- PADS Designer 확장 - 내부 커스텀 기능 : 심볼 출력
 - 이 스크립트는 회로도 심볼을 Export 하여 라이브러리를 구축 때 활용 합니다.

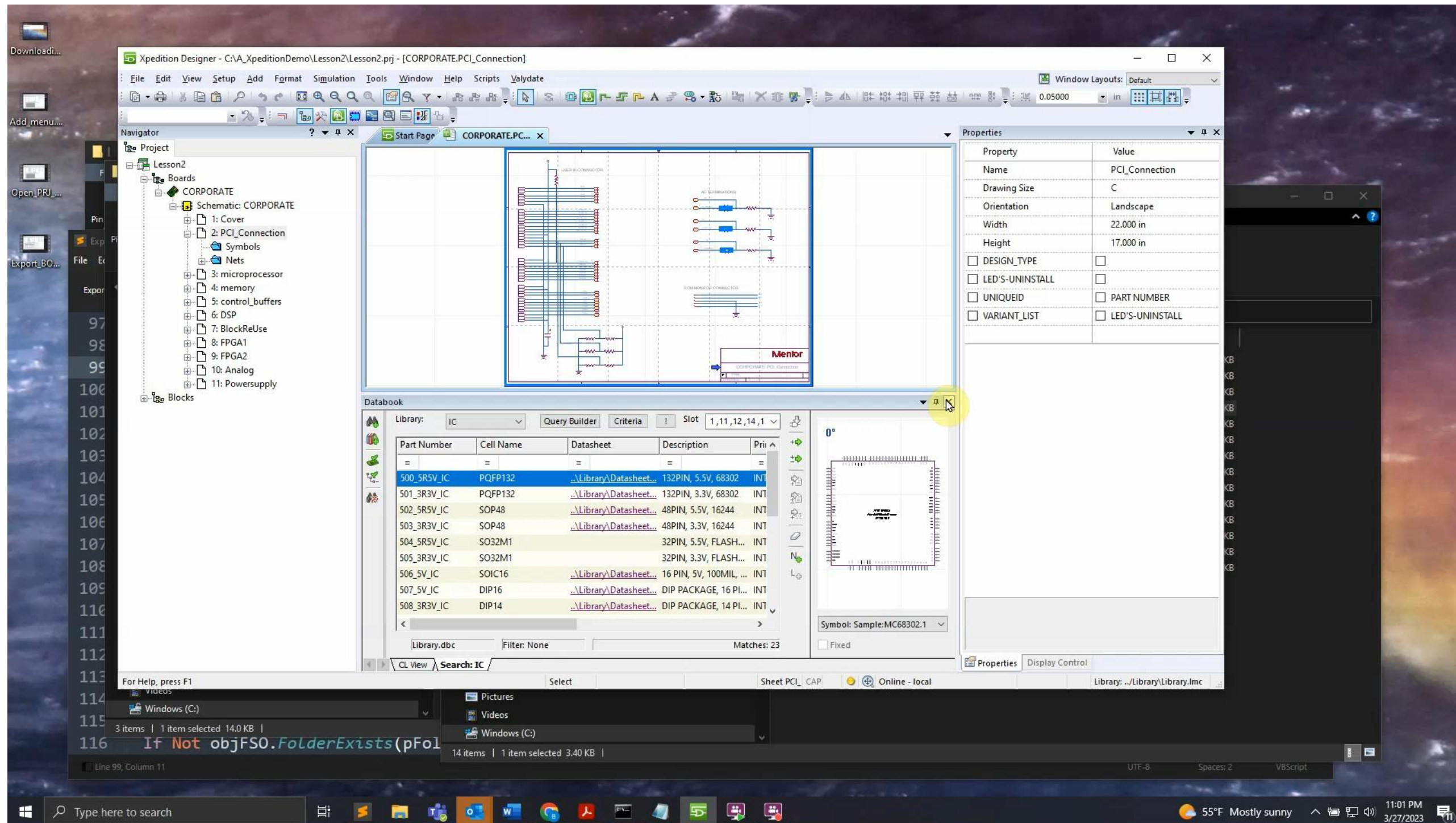

PADS Designer 활용

- PADS Designer 확장 – 내부 커스텀 기능 : 링크/포트 디스플레이 ON/OFF
– Display Control에서 포트와 링크의 이름을 일괄적으로 켜고 끄는 것이 가능합니다.

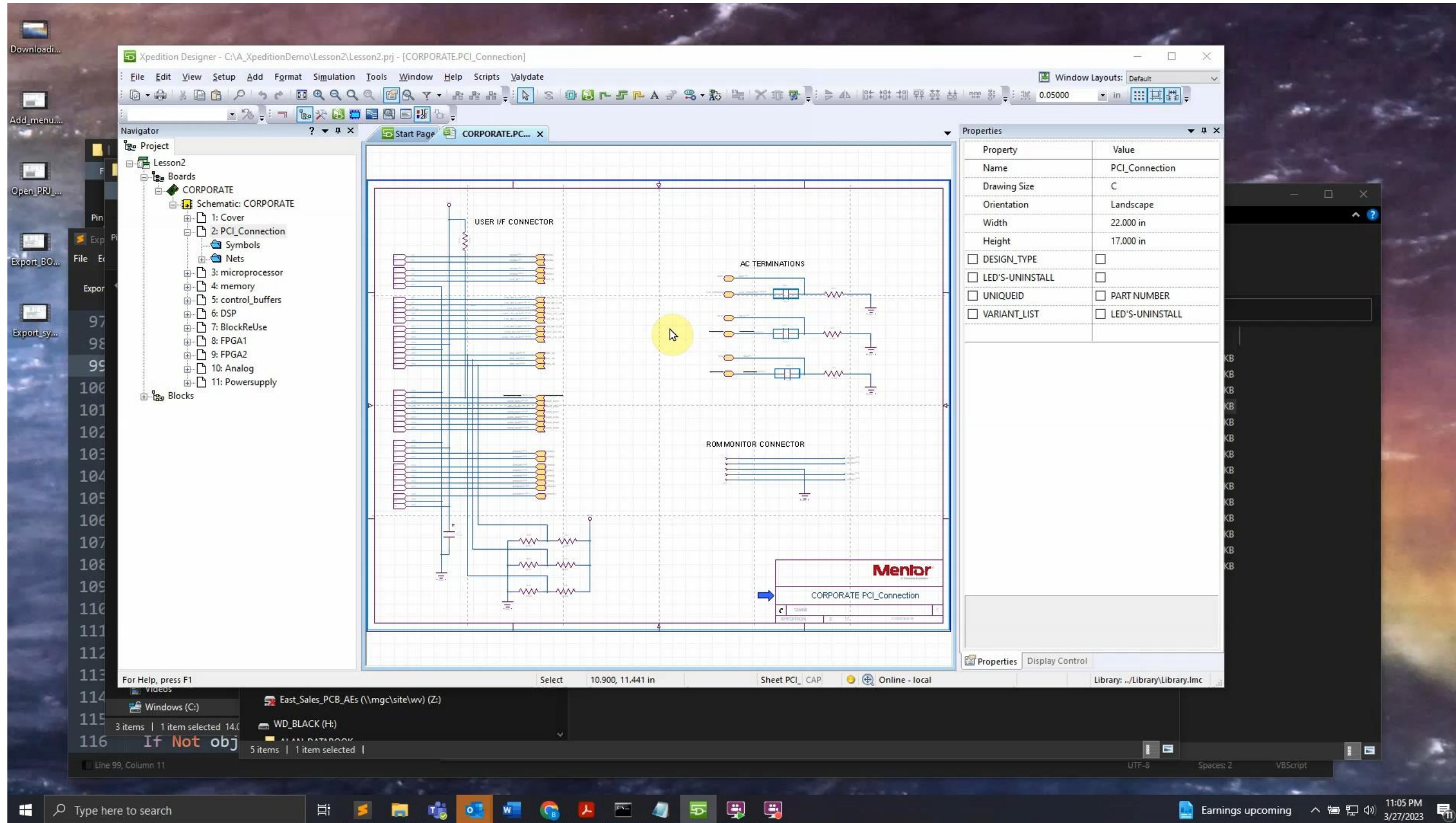

PADS Designer 활용

- PADS Designer 확장 - 내부 커스텀 기능 : Reference 할당 여부 찾기
 - 이 스크립트는 마지막으로 사용하거나 누락된 Reference의 표와 보고서를 생성합니다.

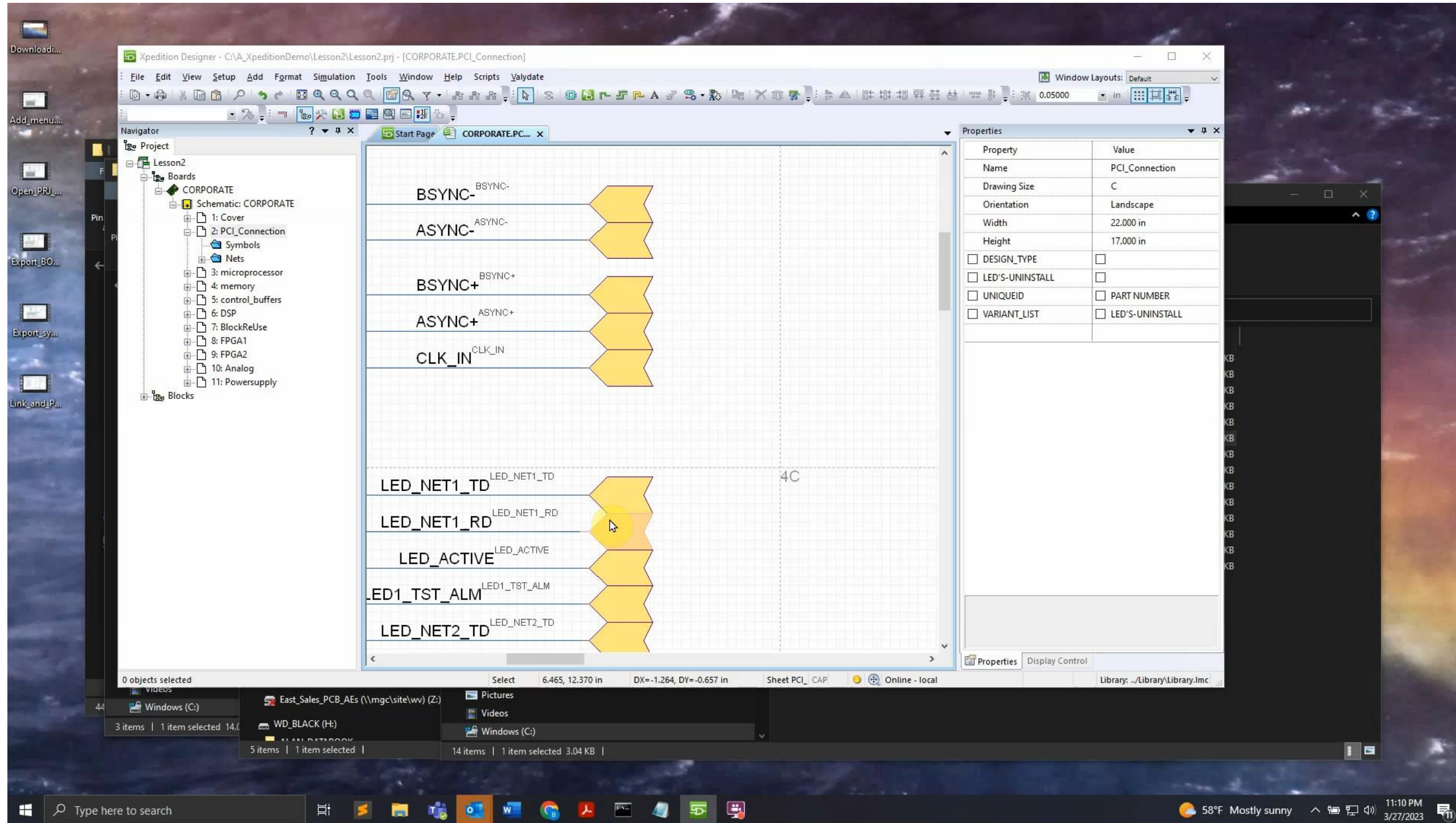

PADS Designer 활용

- PADS Designer 확장 - 내부 커스텀 기능 : 일괄 수정
 - 여러 글꼴을 변경하여 회로도를 일괄 수정하는 데 유용합니다.

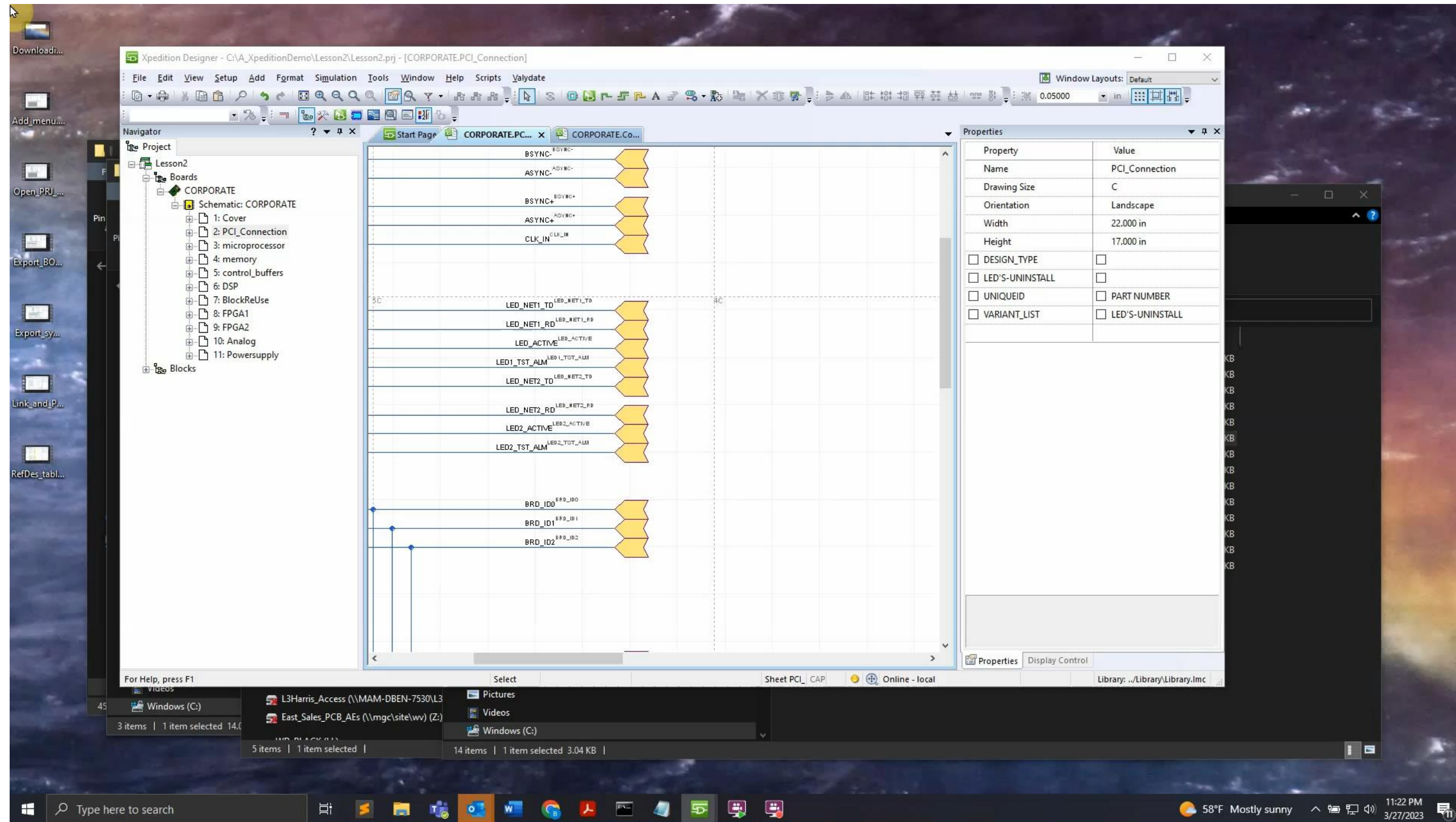

PADS Designer 활용

- PADS Designer 확장 – 내부 커스텀 기능 : 자동 심볼 추가
 - 이 스크립트는 계층 구조 내의 각 네트에 네트 이름 속성을 가진 심볼을 추가합니다.

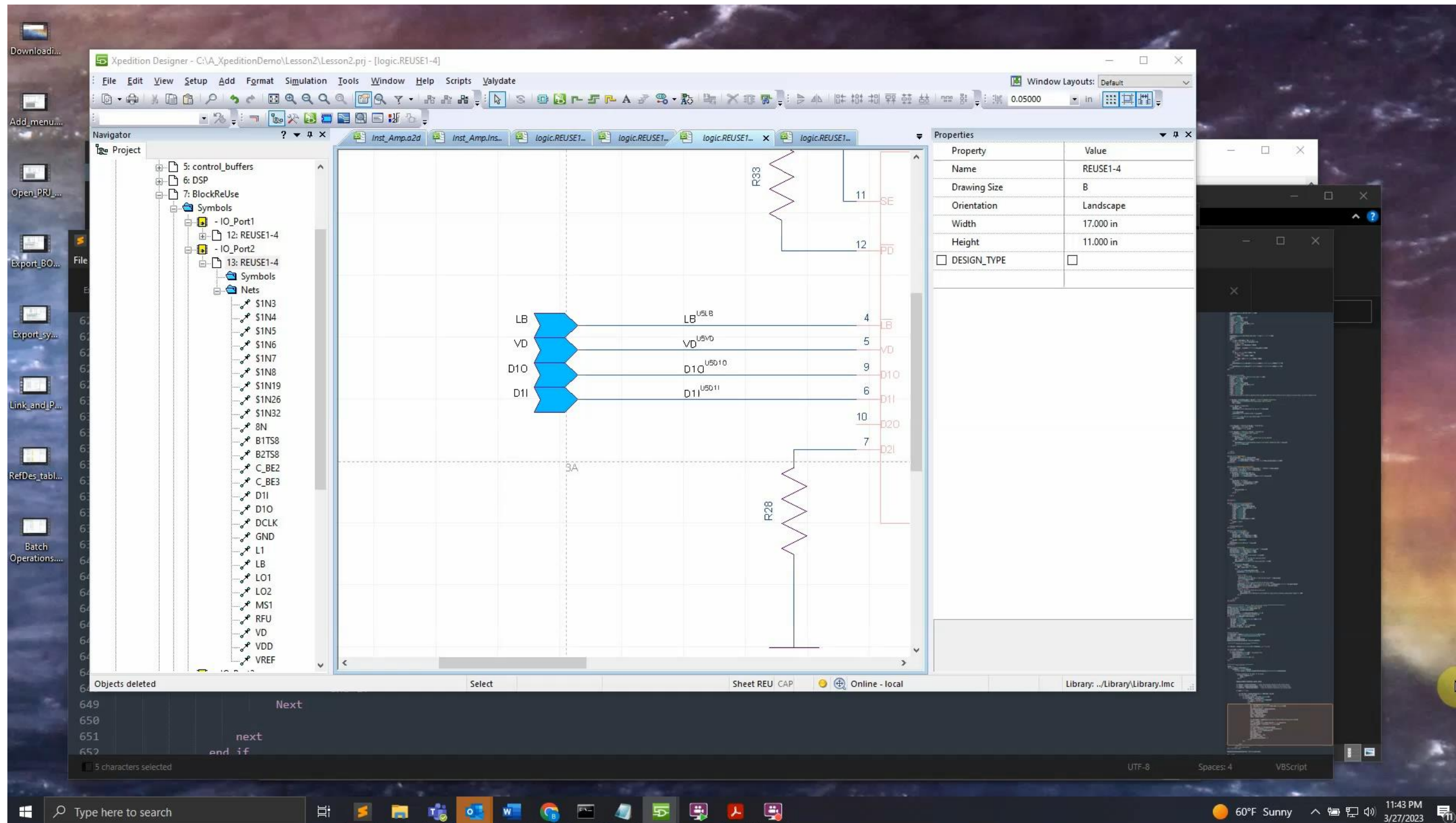

PADS Designer 활용

- PADS Designer 확장 – 내부 커스텀 기능 : net 리포트
 - 이 스크립트는 이름이 없거나 표시되지 않는 네트를 찾는 데 사용할 수 있습니다.

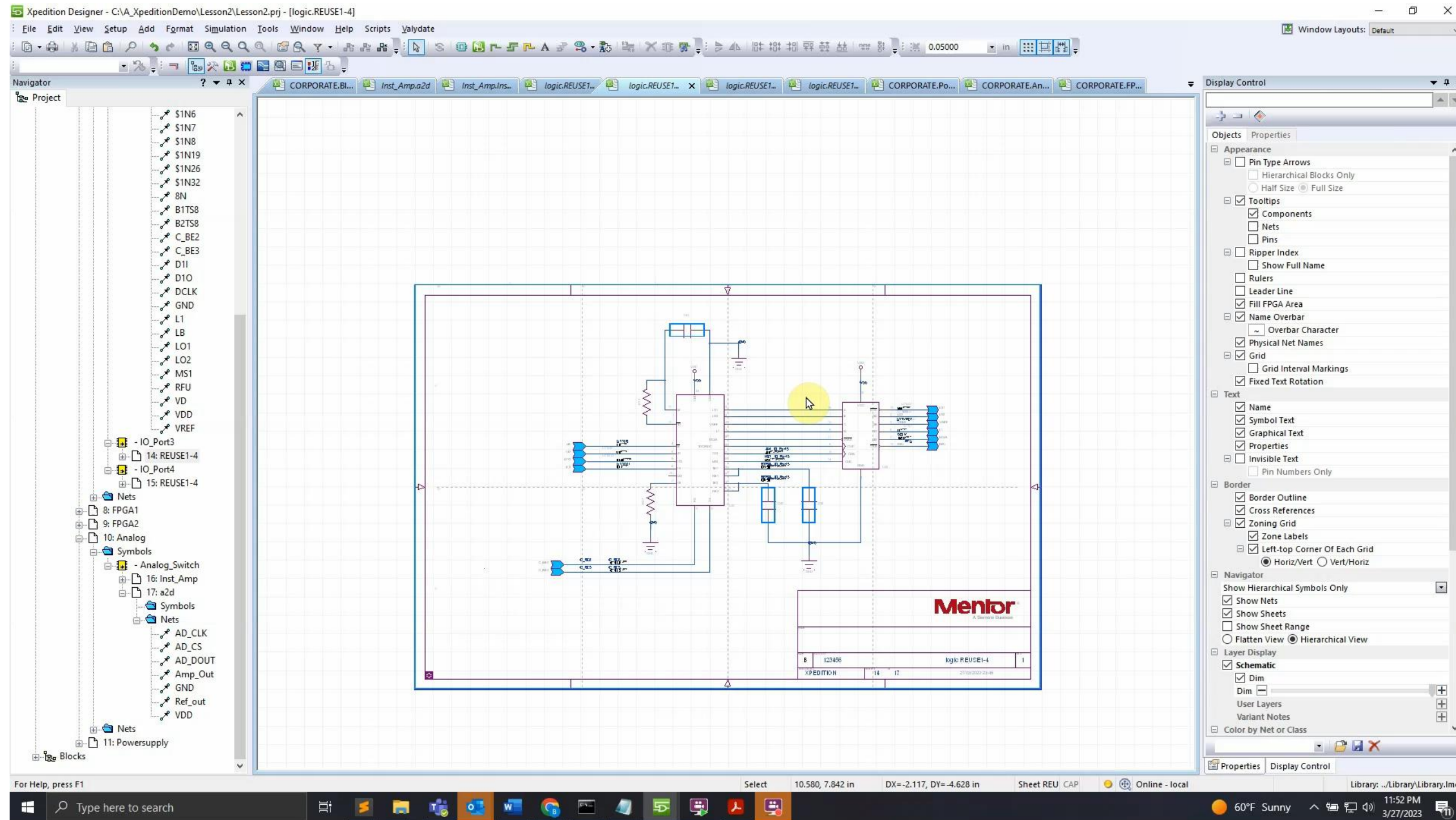

PADS Designer 활용

- PADS Designer 확장 - 외부 커스텀 기능
 - PADS Designer에서 출력하거나 관련된 파일로 기능을 구현합니다.
 - 출력하거나 관련된 파일을 기반으로 Python등을 활용하여 가능합니다.

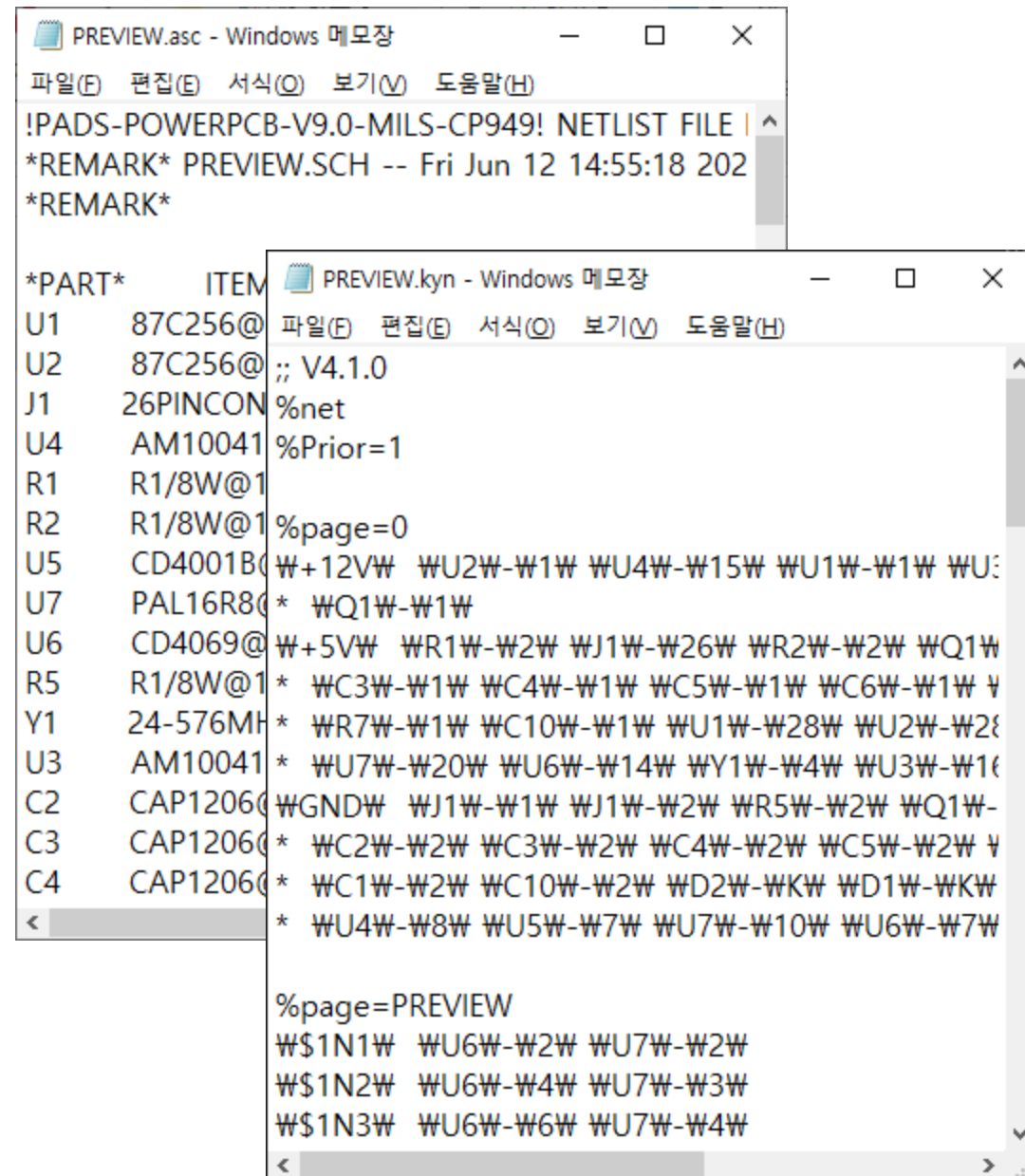

```

!PADS-POWERPCB-V9.0-MILS-CP949! NETLIST FILE | ^
*REMARK* PREVIEW.SCH -- Fri Jun 12 14:55:18 202
*REMARK*

*PART*
ITEM
U1 87C256@
U2 87C256@ ;; V4.1.0
J1 26PINCON %net
U4 AM10041 %Prior=1
R1 R1/8W@1
R2 R1/8W@1 %page=0
U5 CD4001B W+12VW WU2W-W1W WU4W-W15W WU1W-W1W WU:
U7 PAL16R8 * WQ1W-W1W
U6 CD4069@ W+5VW WR1W-W2W WJ1W-W26W WR2W-W2W WQ1W
R5 R1/8W@1 * WC3W-W1W WC4W-W1W WC5W-W1W WC6W-W1W W
Y1 24-576MH * WR7W-W1W WC10W-W1W WU1W-W28W WU2W-W28
U3 AM10041 * WU7W-W20W WU6W-W14W WY1W-W4W WU3W-W16
C2 CAP1206 W GNDW WJ1W-W1W WJ1W-W2W WR5W-W2W WQ1W-
C3 CAP1206 * WC2W-W2W WC3W-W2W WC4W-W2W WC5W-W2W W
C4 CAP1206 * WC1W-W2W WC10W-W2W WD2W-WKW WD1W-WKW
* WU4W-W8W WU5W-W7W WU7W-W10W WU6W-W7W

%page=PREVIEW
W$1N1W WU6W-W2W WU7W-W2W
W$1N2W WU6W-W4W WU7W-W3W
W$1N3W WU6W-W6W WU7W-W4W
  
```

스크립트

프로그래밍

결과 파일



PADS Designer 활용

- PADS Designer 확장 – 외부 커스텀 기능 : .asc의 netlist를 keyin으로 변환
 - PADS Logic등에서 출력한 PADS용 Netlist(.asc)를 Xpedition Standard의 Layout Netlist(.kyn)로 변환 합니다.

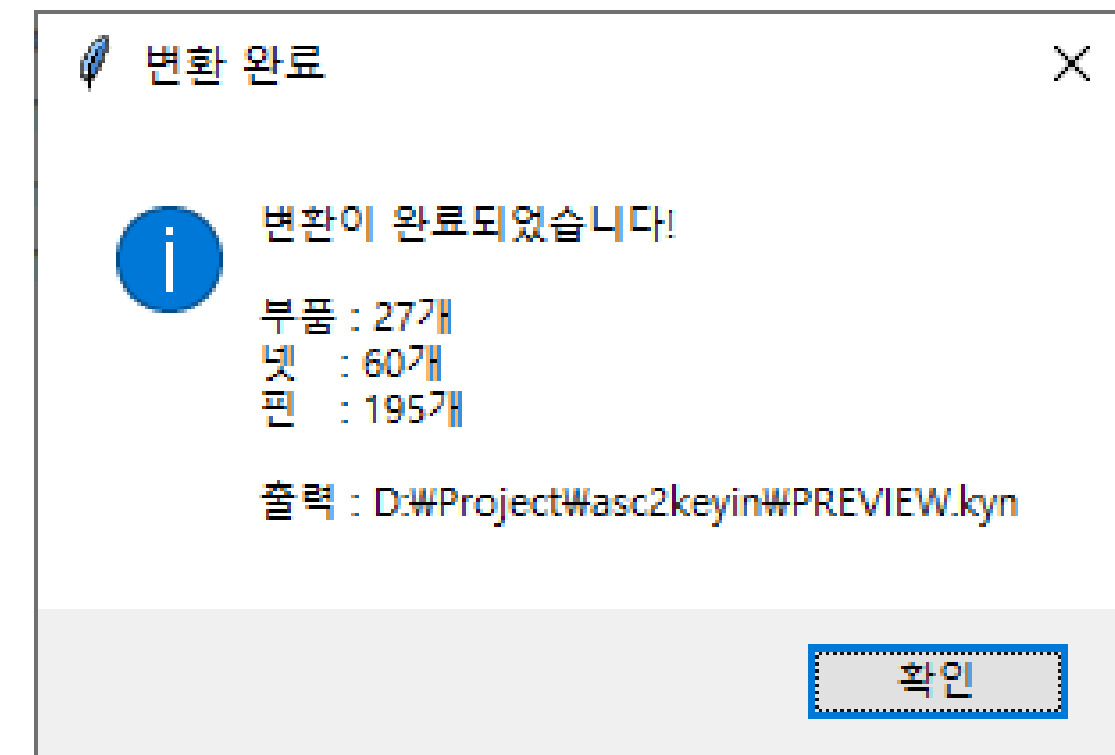
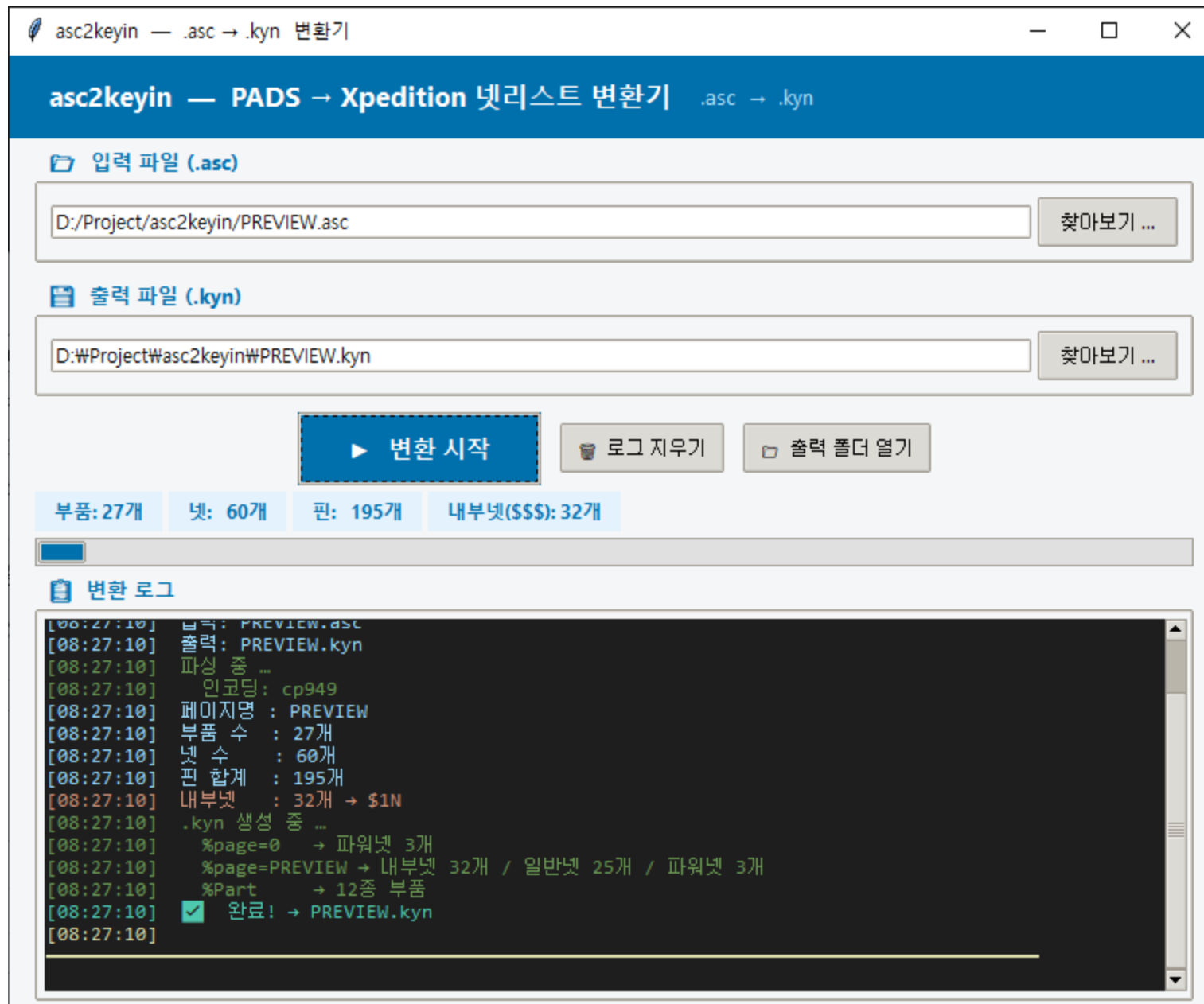

PADS Designer 활용

- PADS Designer 확장 – 외부 커스텀 기능 : netlist Compare 기능
 - Revision된 버전의 회로도를 기존 버전의 회로도와 Keyin Netlist로 비교하는 기능

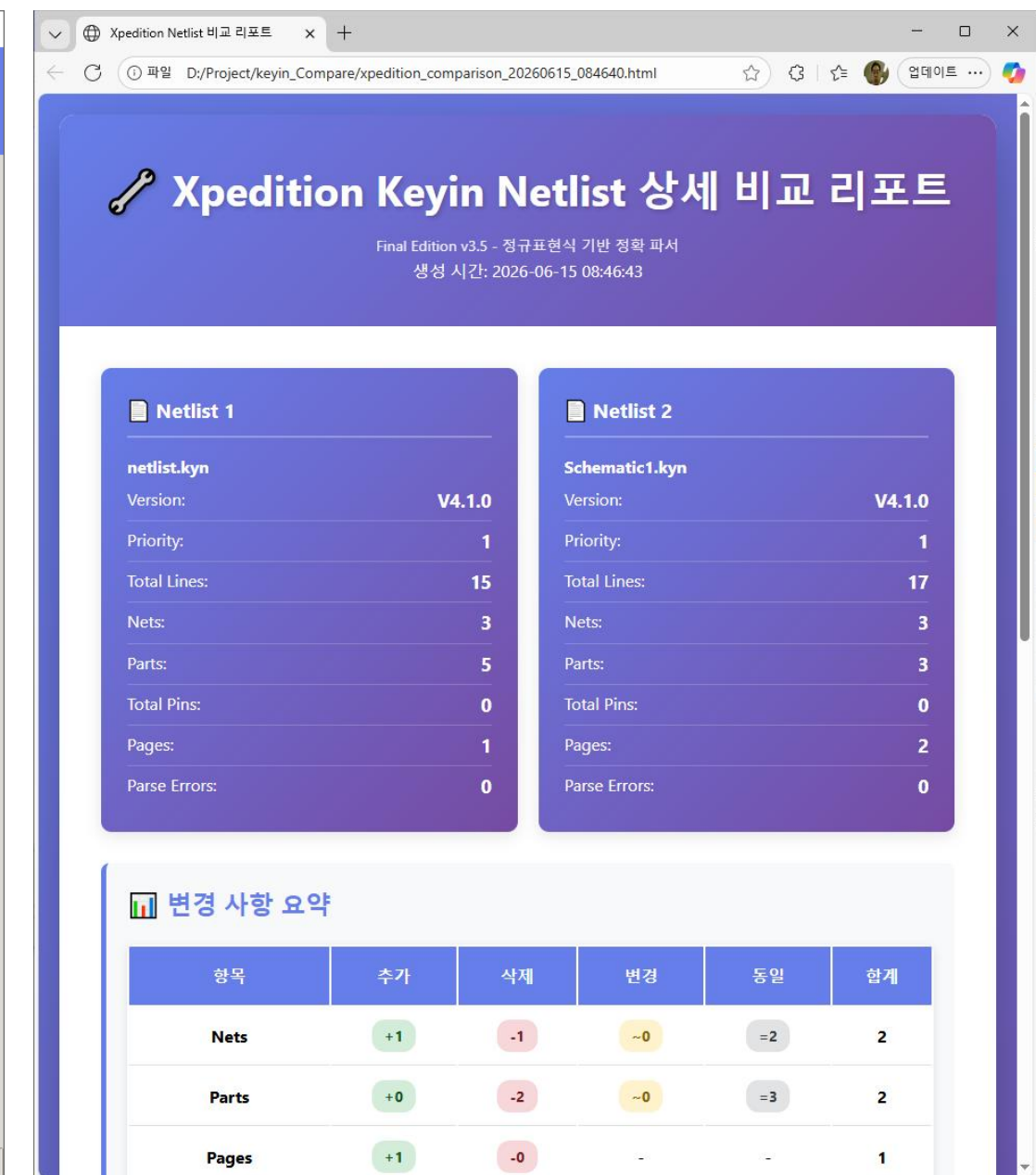
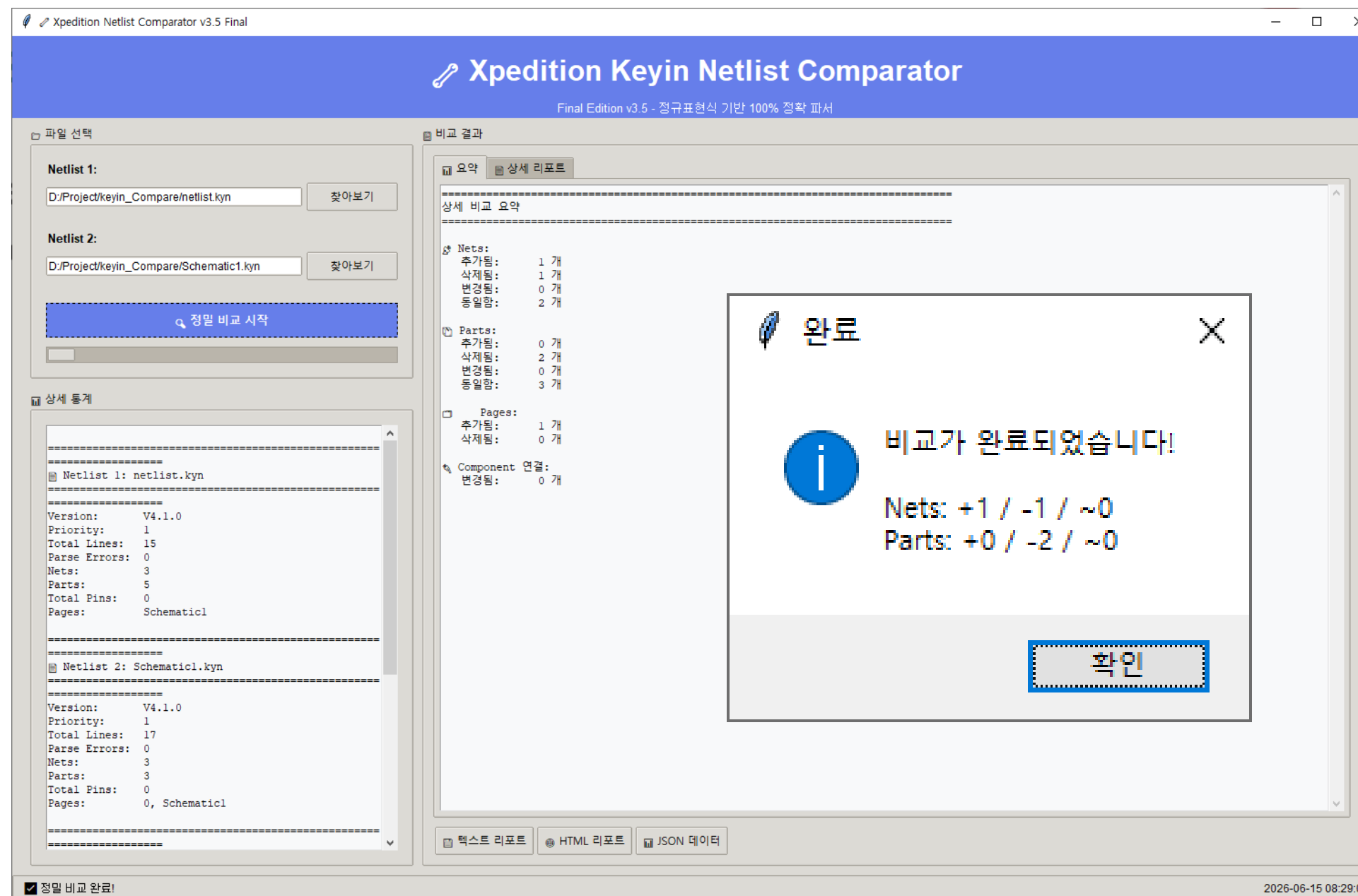

PADS Designer 활용

- PADS Designer 확장 – 외부 커스텀 기능 : 라이선스 분석
 - PADS 라이선스 로그파일로 확인 가능한 사용률 분석 프로그램
 - 시간별, 사용자별 라이선스 통계와 라이선스 부족분 예측하고 결과파일 엑셀출력

The image displays the PADS License Analyzer v2.5 software interface, which provides a comprehensive overview of license usage and denial statistics. The main dashboard includes several key metrics:

- Summary Metrics:** 총 이벤트 (Total Events) 144, 체크아웃 (Checkouts) 45, 반납 (Returns) 23, 거부 (Denials) 76, 사용자 (Users) 10, 평균(분) (Average) 395.2.
- Feature Checkout:** A bar chart showing the number of checkouts for various features. The most used feature is pdsstd_c with 29 checkouts.
- Usage Ratio:** A pie chart showing the distribution of license usage across different features. pdsstd_c accounts for 64.4% of the total usage.
- DENIED Status:** A detailed view of denied licenses, including a warning: "DENIED 이벤트 기반 라이선스 부족 예측 | 권장 추가 수량 = 5분 피크(60%) + 시간 평균(40%) 가장 평균". It provides metrics such as 거부 피쳐 수 (2), 총 거부 건수 (76), 피해 사용자 (12), 최대 동시 거부 (9), 평균 거부/시간 (6.0), and 총 권장 추가 (12).
- Recommended Additional Licenses:** A bar chart comparing recommended licenses (orange) and average denied licenses per hour (blue) for pdsstd_c and pdsstdplus_c.
- Excel Output:** A screenshot of an Excel spreadsheet titled "사용자별 통계" (User-wise Statistics), which exports the license usage data into a structured table.

체크아웃	총 사용(분)	평균 세션(분)	사용 피쳐
12	3337.8	278.2	m3dpdfoutput, m3dplugin, pdsstd_c
7	834.3	119.2	pdsstd_c, pdsstdplus_c
7	835.4	119.3	pdsstd_c, pdsstdplus_c
5	3335.9	667.2	m3dpdfoutput, m3dplugin, pdsstd_c, pdslogic
3	834.6	278.2	pdsstd_c, pdsstdplus_c
3	834.5	278.2	pdsstd_c
3	2502.4	834.1	plogshell, plogpdf, pdsstd_c
2	834.1	417.1	pdsstd_c
2	833.6	416.8	pdsstd_c, pdsstdplus_c
1	835.2	835.2	pdsstd_c

감사합니다.